

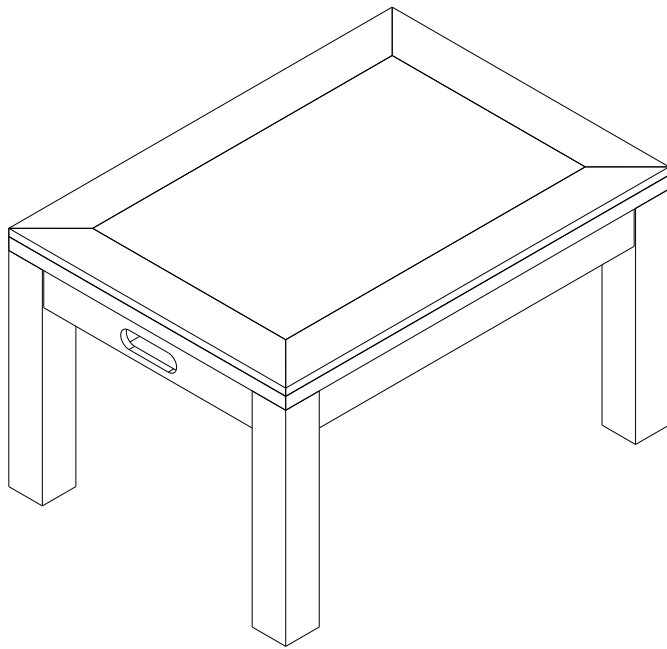









BUMPER TABLE



BUMPER TABLE ASSEMBLY INSTRUCTIONS

HARDWARE

PACKAGE	ITEM#	SAMPLE	DESCRIPTION	QTY.
	H1		HEX HEAD CROSS BOLT 5/16" X 2"(M8X51mm)	24
	H2		FLAT WASHER 5/16" I.D.	24
	H3		FLAT HEAD SCREW 8# X 2"(M4X50mm)	8
	H4		HEX HEAD CROSS BOLT 3/8" X 2-3/8"(M10X60mm)	14
	H5		FLAT WASHER 3/8" I.D.	14
	H6		RUBBER DOT	12
	H7		FLAT HEAD SCREW 8# X 1-1/4"(M4X32mm)	12
	H8		STUD BOLT 5/16" X 3-1/2"(M8X88mm)	4
	H9		FLAT WASHER 5/16" I.D.	8
	H10		HEX NUT 5/16" I.D.	8

COMPONENT PARTS







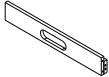
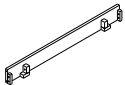
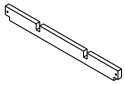
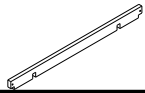
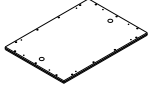

PACKAGE	ITEM#	SAMPLE	DESCRIPTION	QTY.
	1		LEG	4
	2		SHORT APRON	2
	3		LONG APRON	2
	4		CROSS BEAM	2
	5		CENTER BEAM	2
	6		SLATE	1
	7		END TOP RAIL	2
	8		SIDE TOP RAIL	2
	9		TABLE TOP	1
	10		BALL BOX	2
	11		WOOD JOINT	16
	12		BUMPER POST	12
	13		POCKET	2
	14		BISCUIT BOTTLE	4

FIG.1

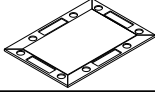
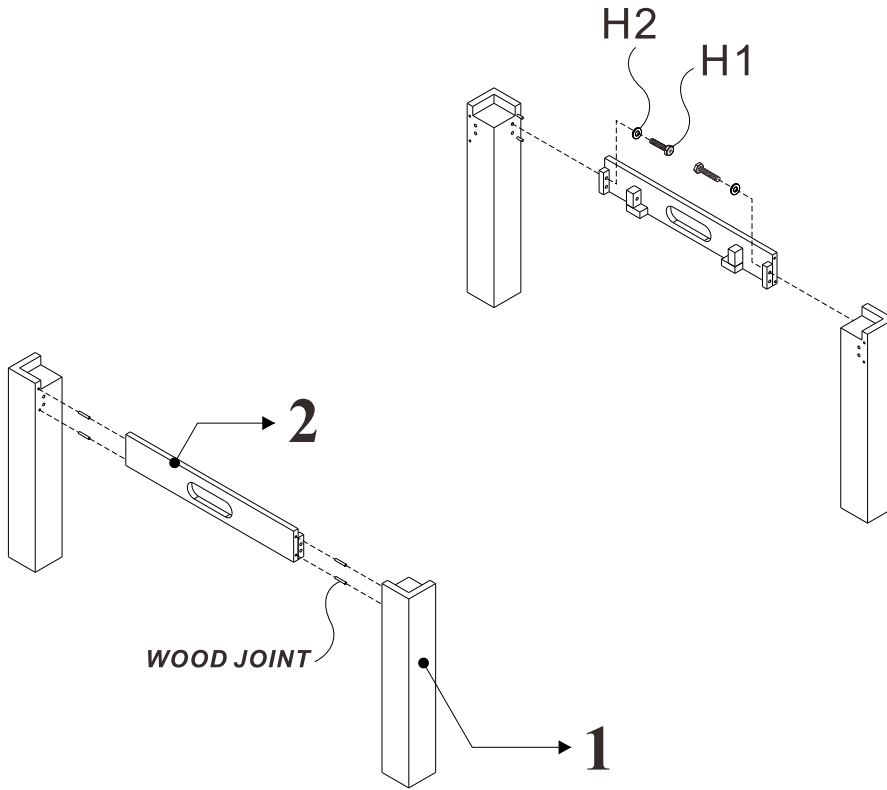

FIG.2

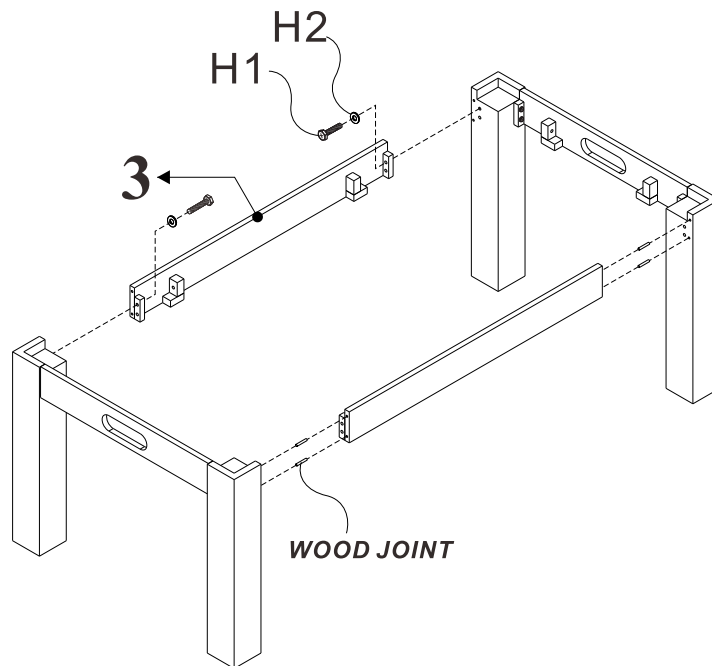

FIG.3

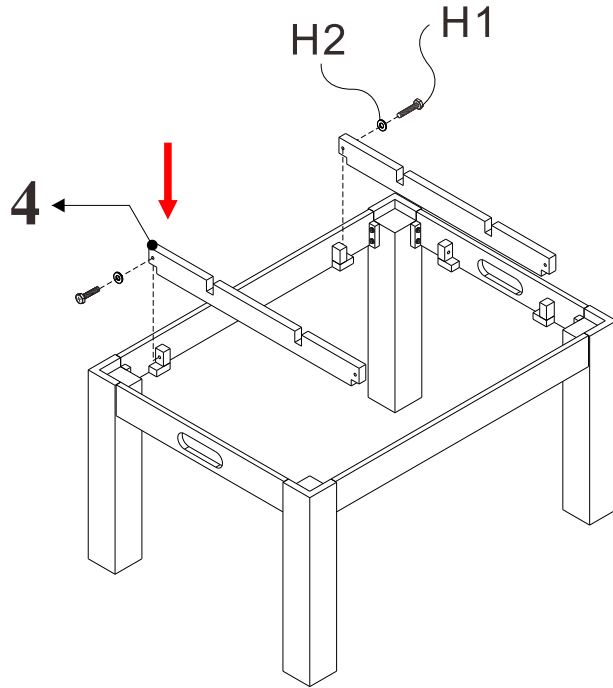

FIG.4

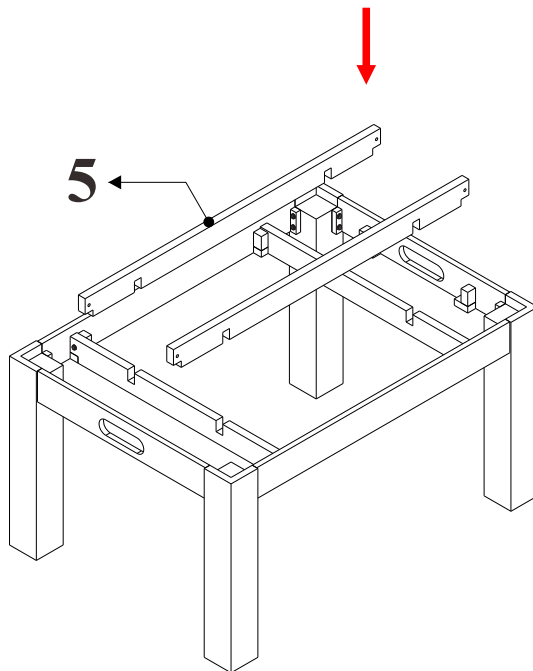

FIG.5

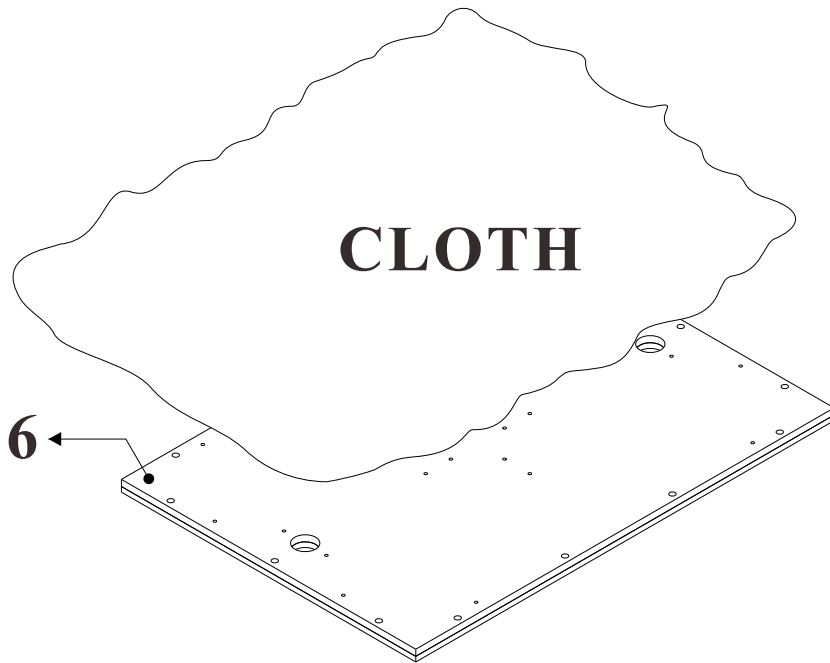

FIG.6

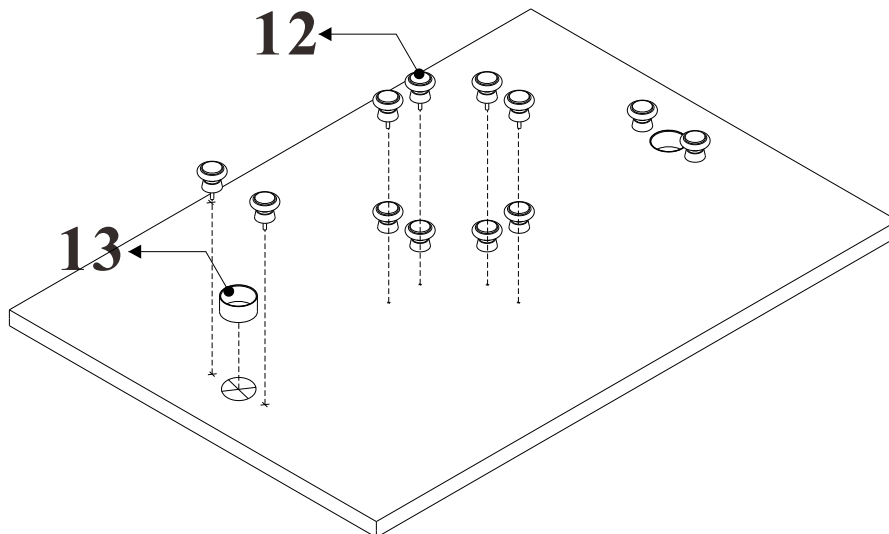

FIG.7

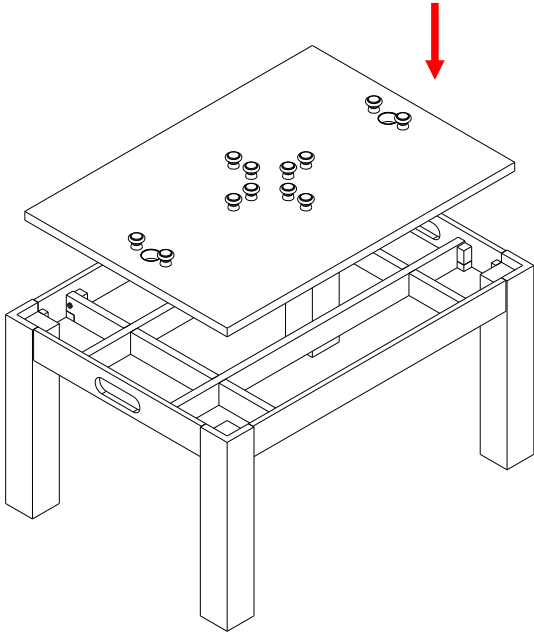

FIG.8

Cut holes in cloth at rail both locations.

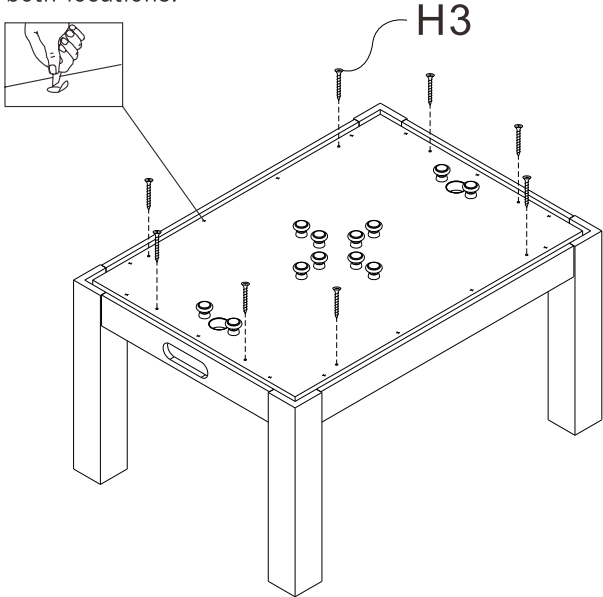

FIG.9

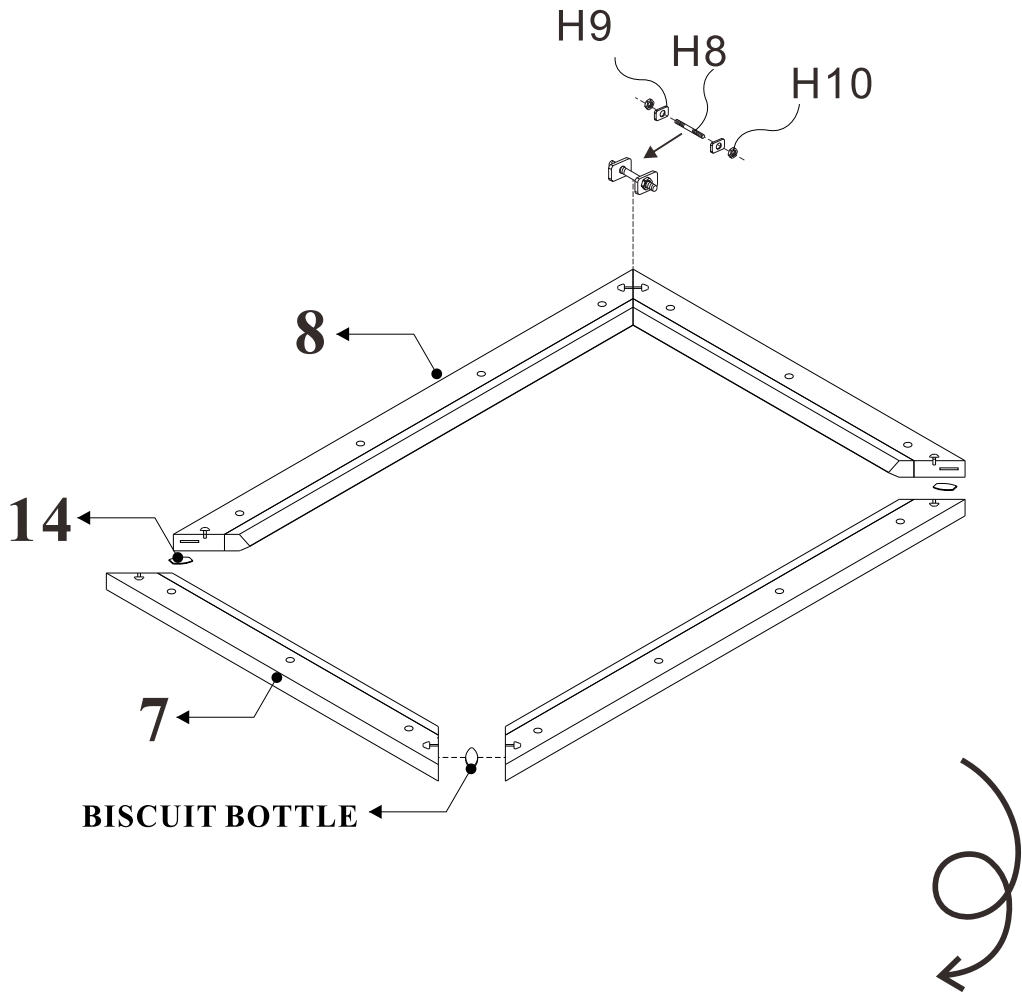
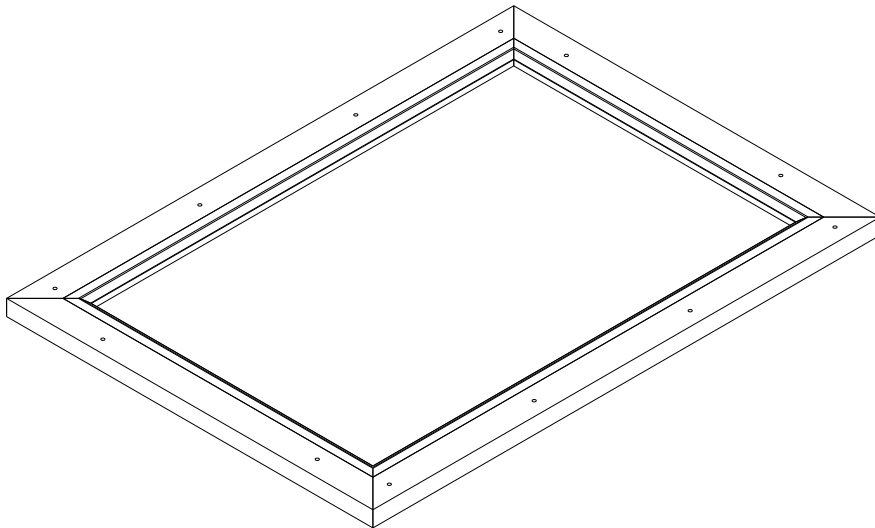
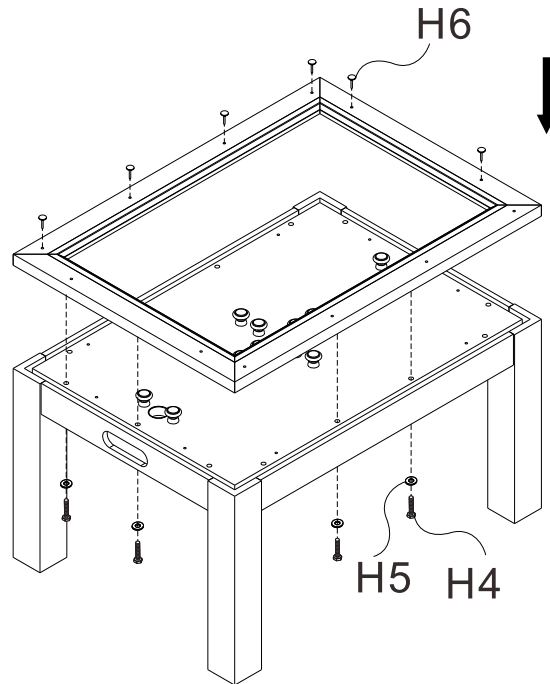

FIG.10



* Insert the H6 into the pre-drilled hole

FIG.11



FINISH

