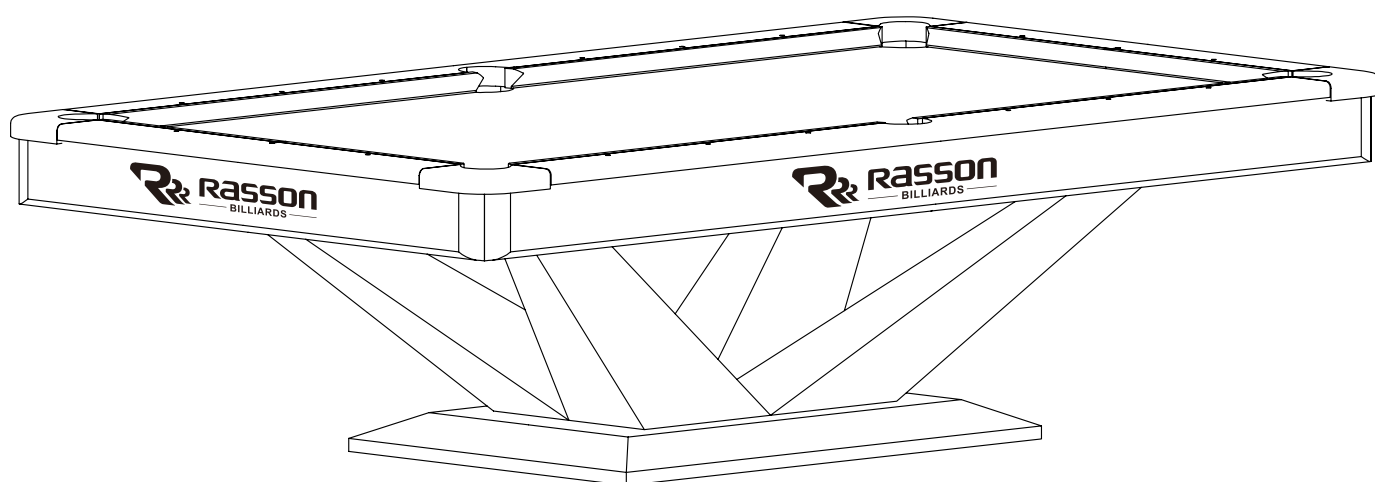

















V 勝利 **II** +
VICTORY









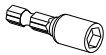


BILLIARDS INSTRUCTION MANUAL

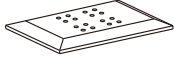
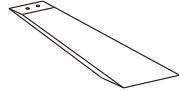
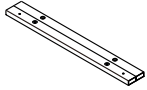



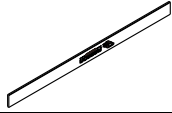
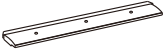

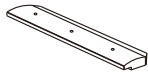
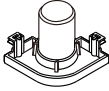

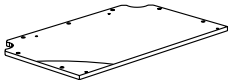
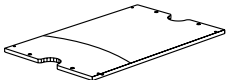
REPLACEMENT PARTS LIST (HARDWARE)

PACKAGE	ITEM #	SAMPLE	DESCRIPTION	QTY.
LEG/PAD	H1		DOUBLE-THREAD SCREW	16
	H2		FLAT WASHER 1/2" I.D.	16
	H3		HEX NUT 1/2" I.D.	16
	H4		HEX HEAD CROSS BOLT 3/8" X 3-1/8"(M10 X 80mm)	8
	H5		FLAT WASHER 3/8" I.D.	8
CABINET	H6		HEX HEAD CROSS BOLT 3/8" x 2-3/8"(M10 x 60mm)	8
	H7		FLAT WASHER 3/8" I.D.	16
	H8		HEX NUT 3/8" I.D.	8
RAIL/POCKET/FRAME/SLATE	H9		INNER HEX BOLT 1/4" X 1-3/4"(M6 X 45mm)	18
	H10		HEX HEAD CROSS BOLT 3/8" X 1-3/8"(M10 X 35mm)	12
	H11		FLAT WASHER 3/8" I.D.	12
	H12		SMALL MACHINE SCREWS 1/4" X 11/16"(M6 X 17mm)	16
	H13		FLAT WASHER 1/4" I.D.	16
	H14		HEX HEAD CROSS BOLT 5/16" X 11/16"(M8 X 17mm)	54
	H15		FLAT WASHER 5/16" I.D.	54

REPLACEMENT PARTS LIST (HARDWARE)

PACKAGE	ITEM #	SAMPLE	DESCRIPTION	QTY.
RAIL/POCKET/FRAME/SLATE	H16		HEX HEAD CROSS BOLT 3/8" X 2-3/8"(M10 X 60mm)	24
	H17		FLAT WASHER 3/8" I.D. (THICK)	24
	H18		SPRING LOCK WASHER 3/8" I.D.	24
	H19		FLAT WASHER 3/8" I.D.	24
	H20		PLASTIC BAYONET (WITHIN POCKET)	/
	H21		METAL BRACKET	18
	H22		WRENCH	1
	H23		SCREWS 8# X 1-1/16"(M4 X 27mm)	4
	H24		SLEEVE	1

REPLACEMENT PARTS LIST

PACKAGE	ITEM #	SAMPLE	DESCRIPTION	QTY.
LEG/PAD	1		PEDESTAL	1
	2		LEG	4
CABINET/FRAME	3		BEAM CONNECTS CABINET & LEG	2
	4		CABINET	1
	5		LEVELBOX PLUS	18
	6		END APRON	2
	7		SIDE APRON	2
TOP RAIL	8		TOP RAIL LEFT SIDE	2
	9		TOP RAIL RIGHT SIDE	2
	10		TOP RAIL END	2
POCKET	11		CORNER POCKET	4
	12		SIDE POCKET	2
SLATE	13		SLATE (LEFT)	1
	14		SLATE (CENTER)	1

REPLACEMENT PARTS LIST

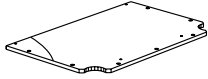


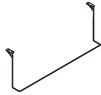

PACKAGE	ITEM #	SAMPLE	DESCRIPTION	QTY.
	15		SLATE (RIGHT)	1
	16		CLOTH	1
	17		METAL CORNER	4
	18		BRIDGE HOLDER	1
	19		TRIANGLE HOLDER	1

FIG.1

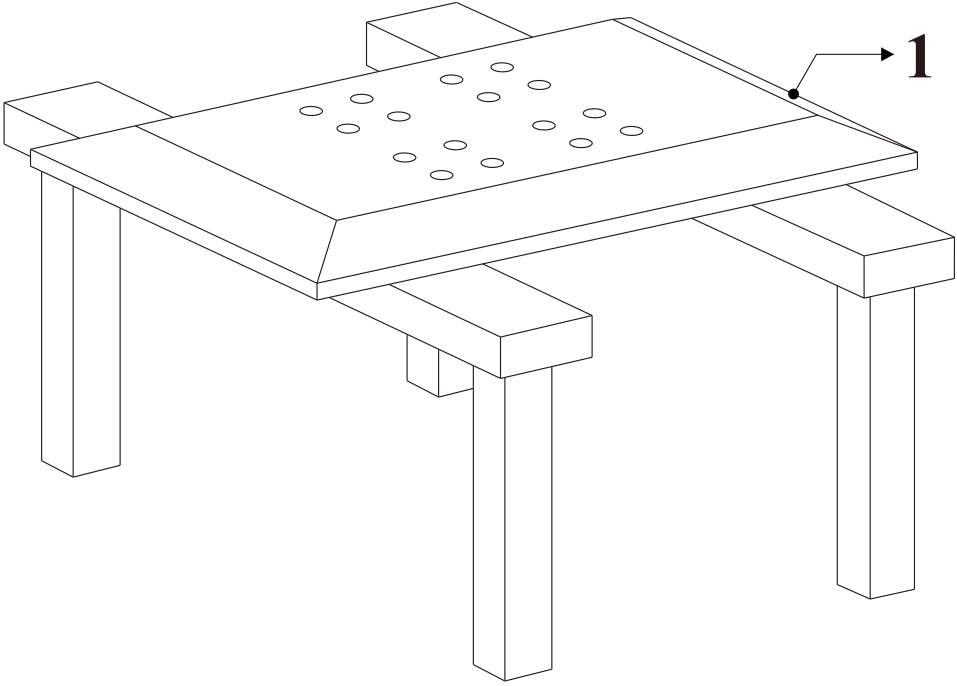


FIG.2

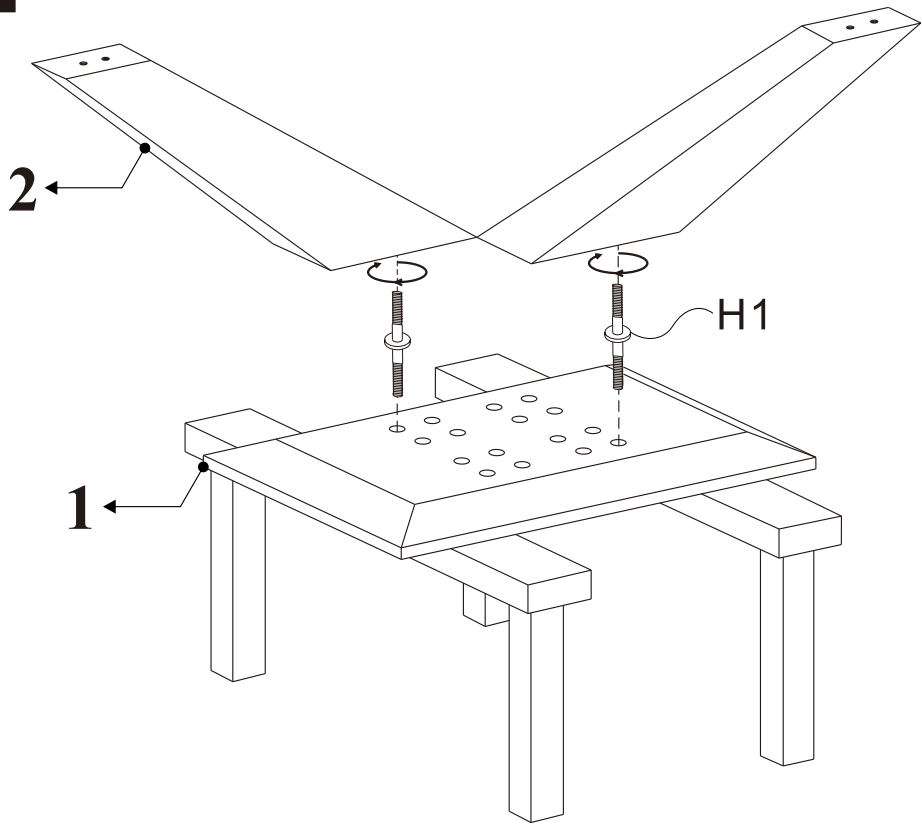


FIG.3

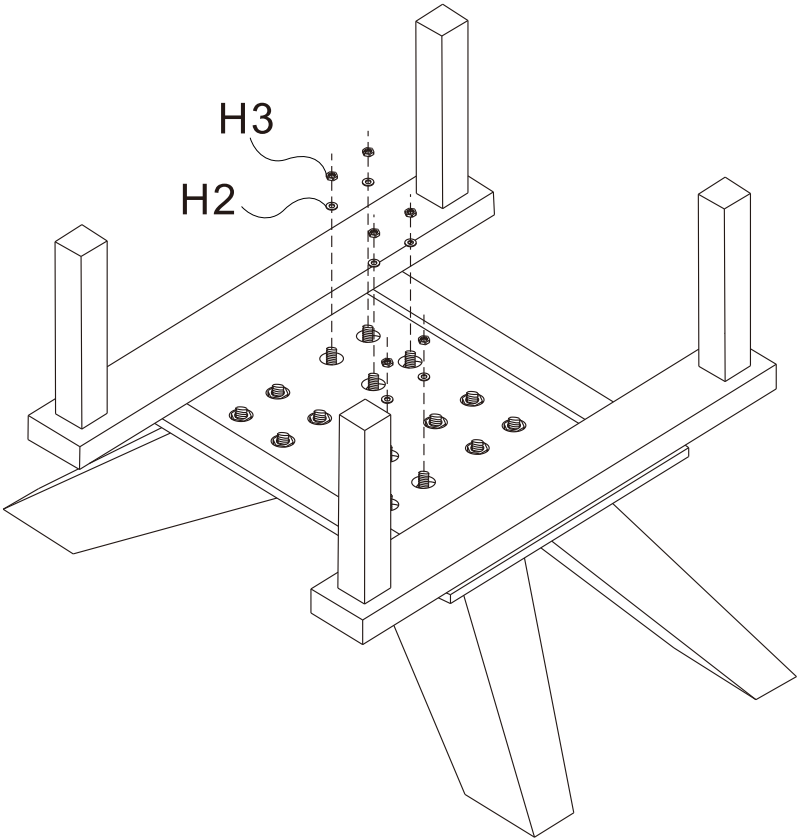


FIG.4

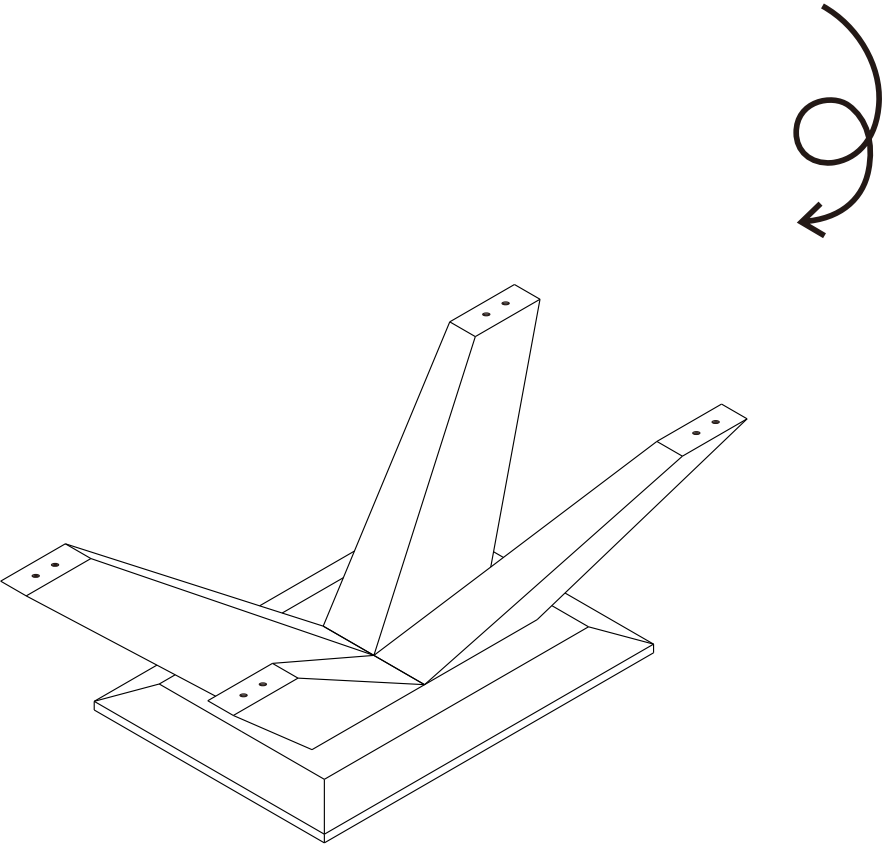


FIG.5

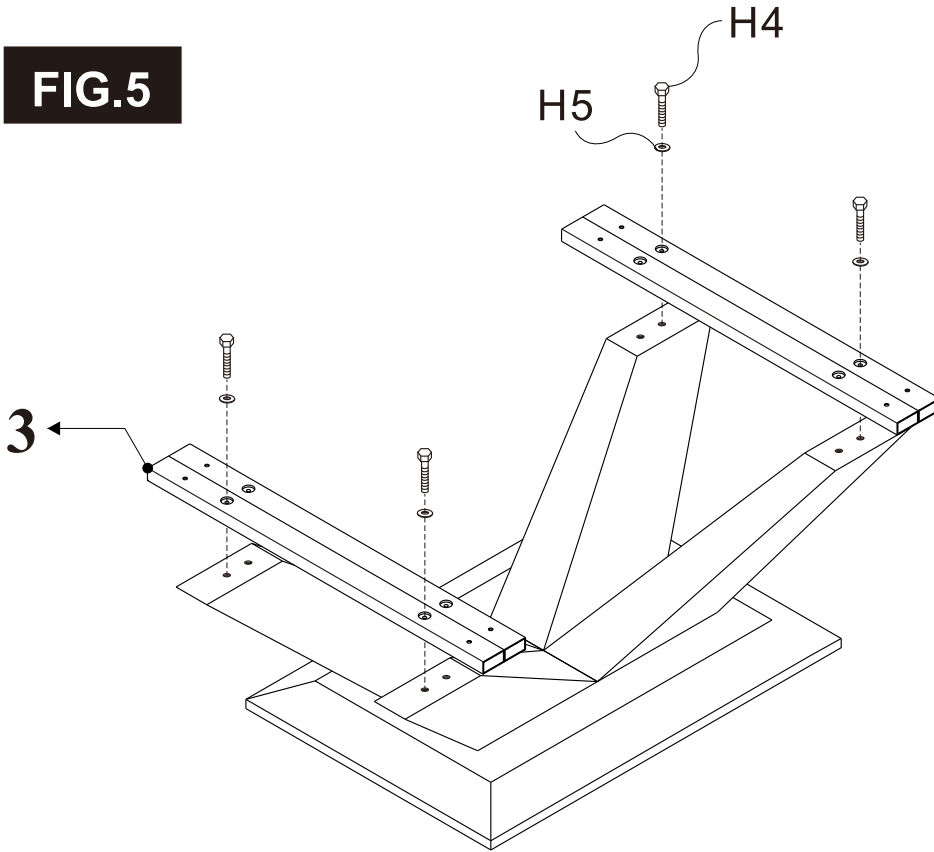


FIG.6

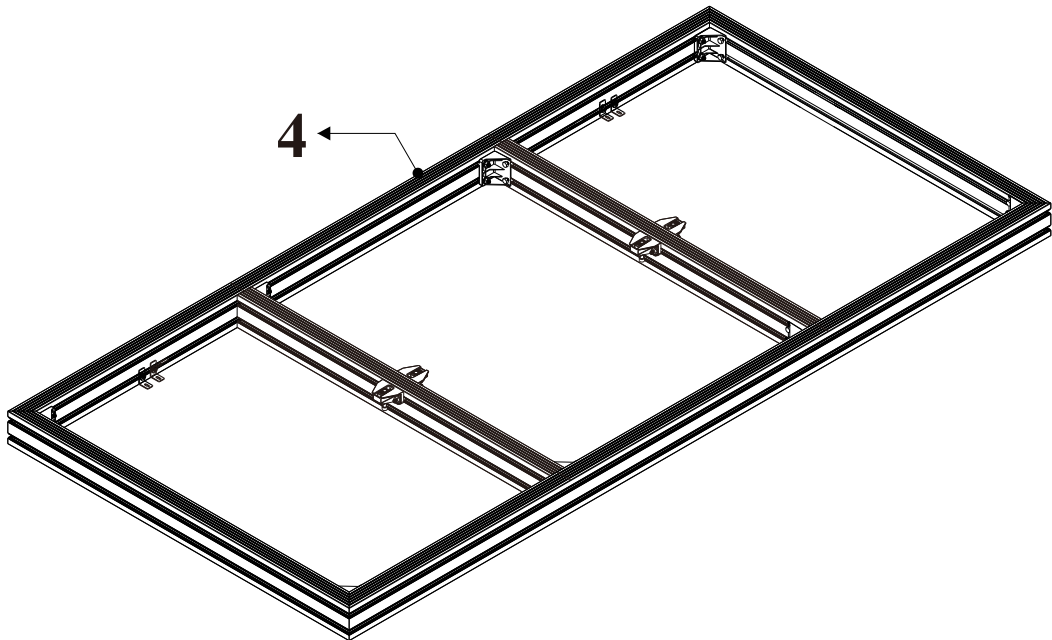


FIG.7



1. Turn the bolt to horizontal position, then insert 5 into aluminium alloy beam.

2. Turn the bolt to vertical position, then tighten the nut.

* Tighten the nut with MANUAL wrench(DON'T use electric tool).

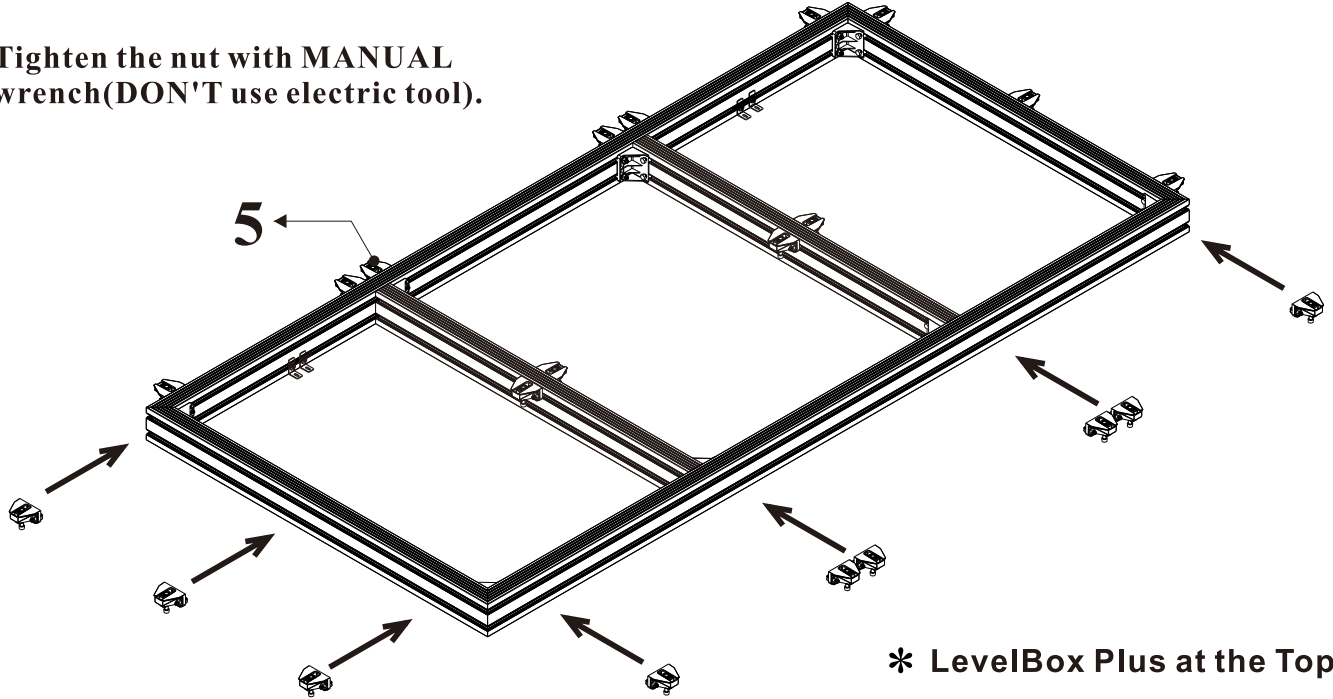


FIG.8

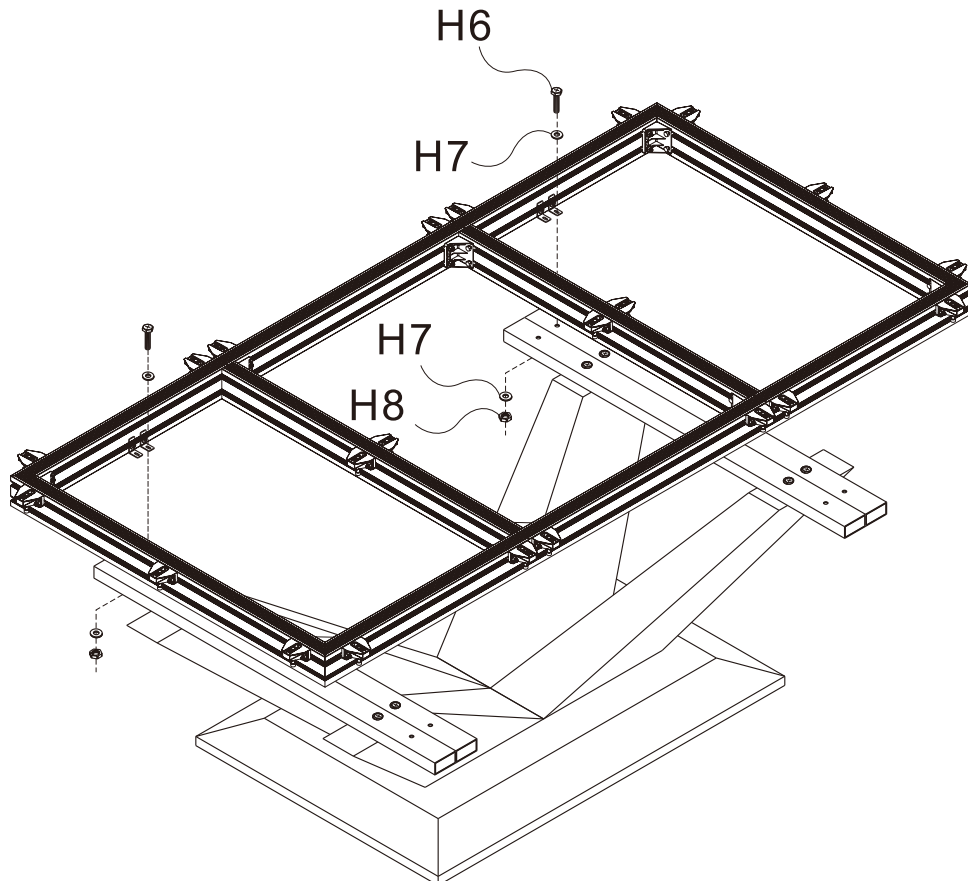
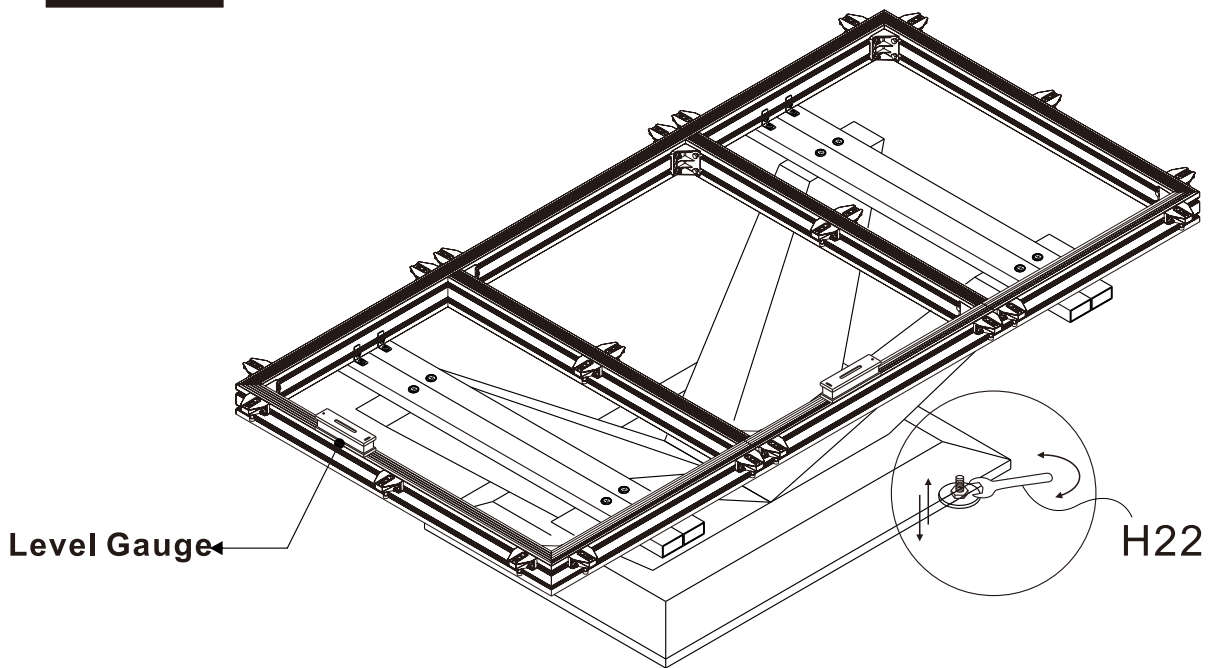
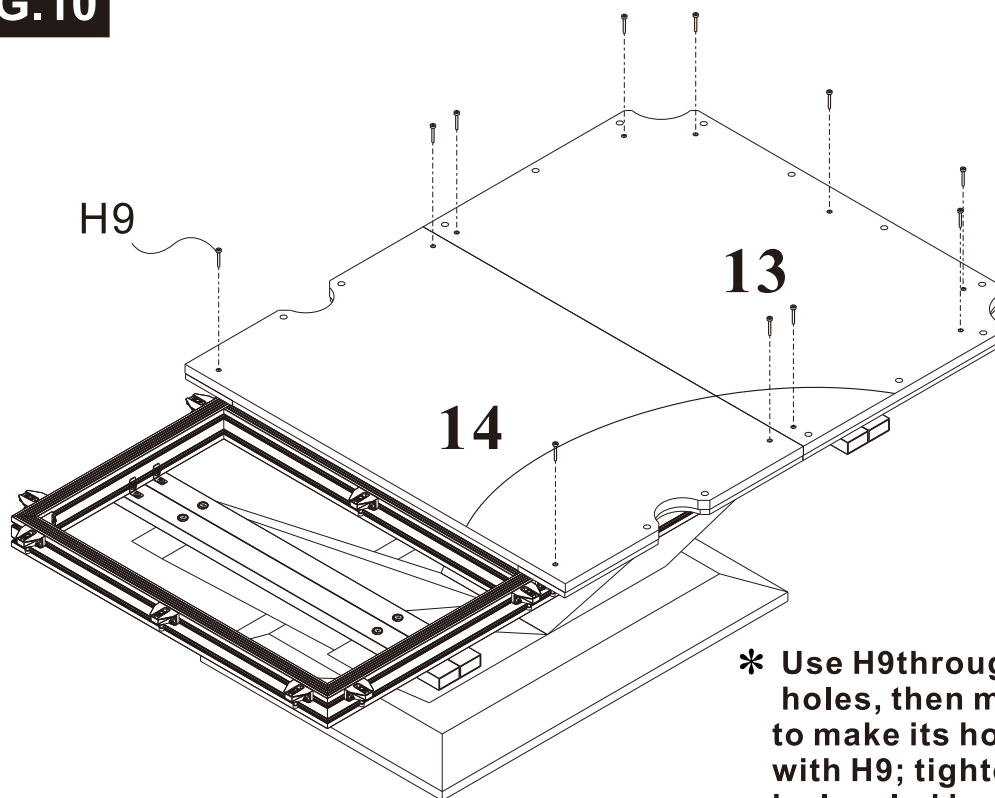


FIG.9



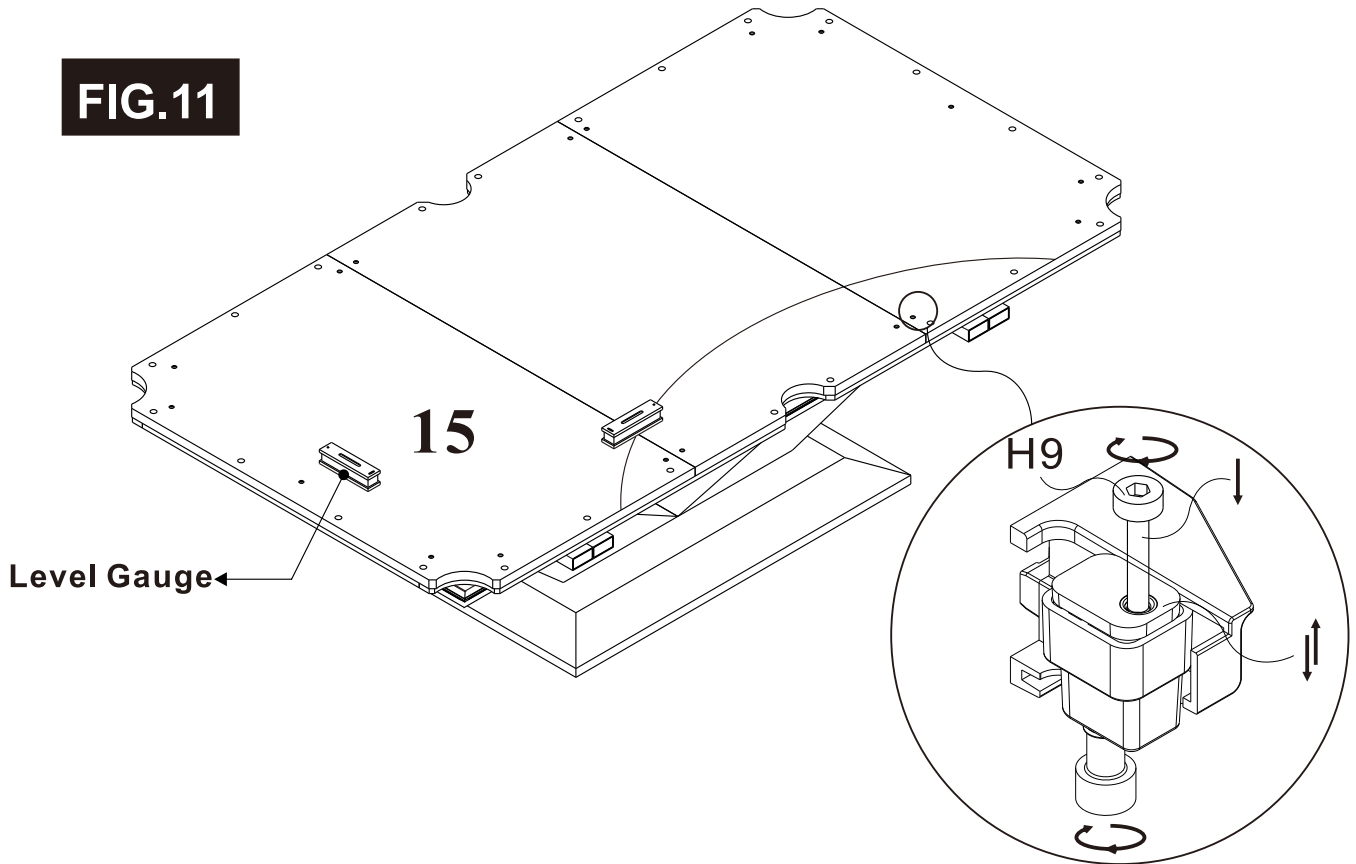
*** Level cabinet through H22 adjusting the height of leg levelers.**

FIG.10



*** Use H9 through slate stepped holes, then move 5 (Levelbox) to make its hole center line up with H9; tighten H9 after slate be leveled in next step.**

FIG.11

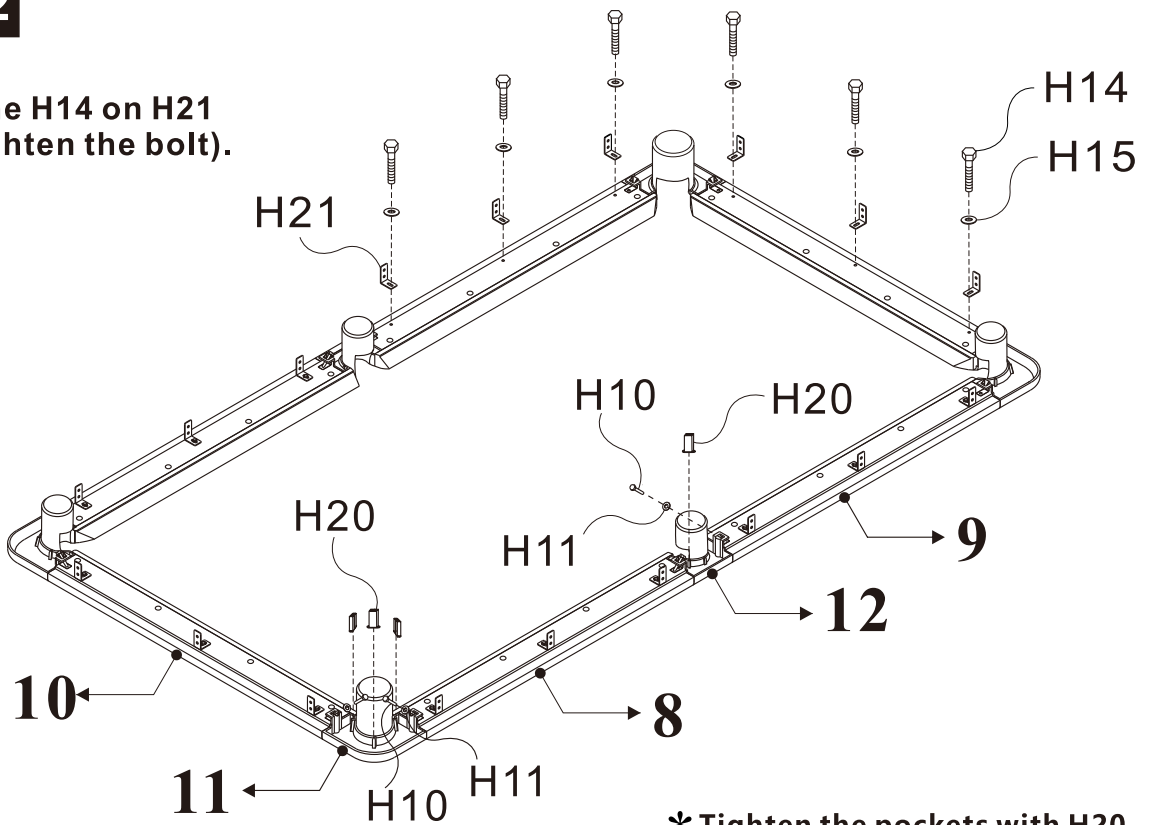


* Level slate with 22 LevelBox adjusters.

* Level slate through spinning hex screws to adjust slate height, then tighten H9 upon slate be leveled.

FIG.12

* Attach the H14 on H21 (don't tighten the bolt).



* Tighten the pockets with H20.

FIG.13

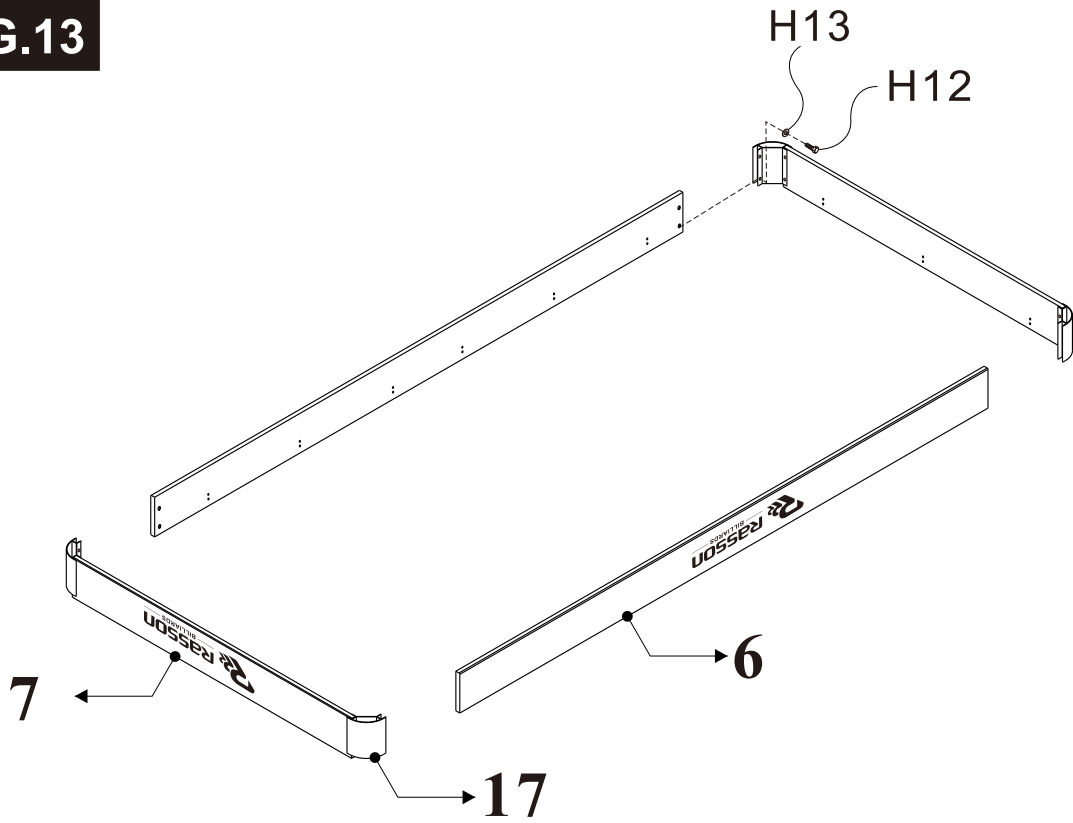


FIG.14

* Tighten H14 after Apron be assembled.

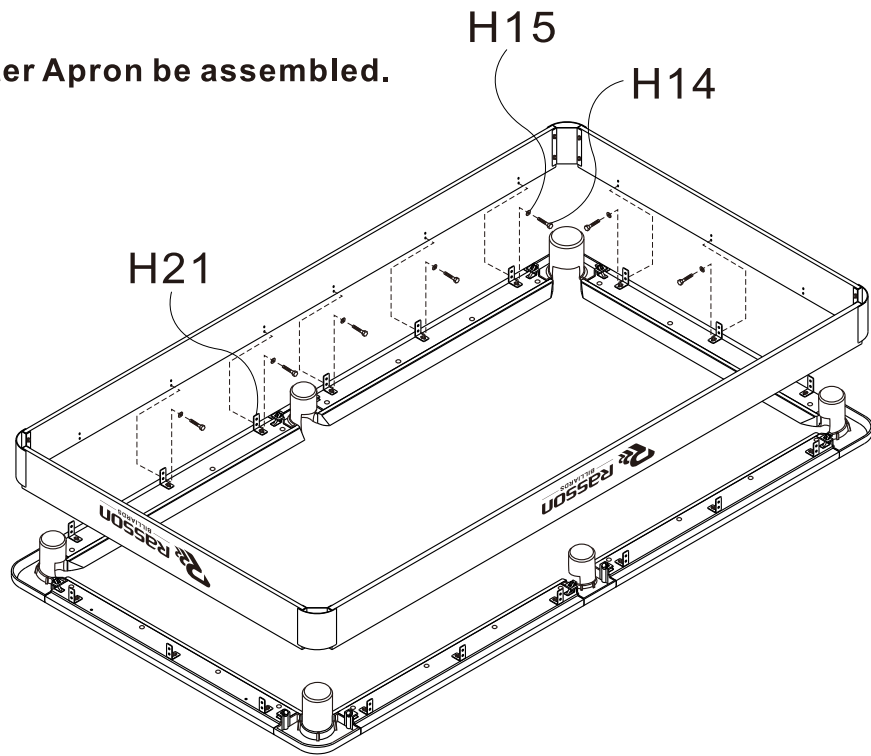
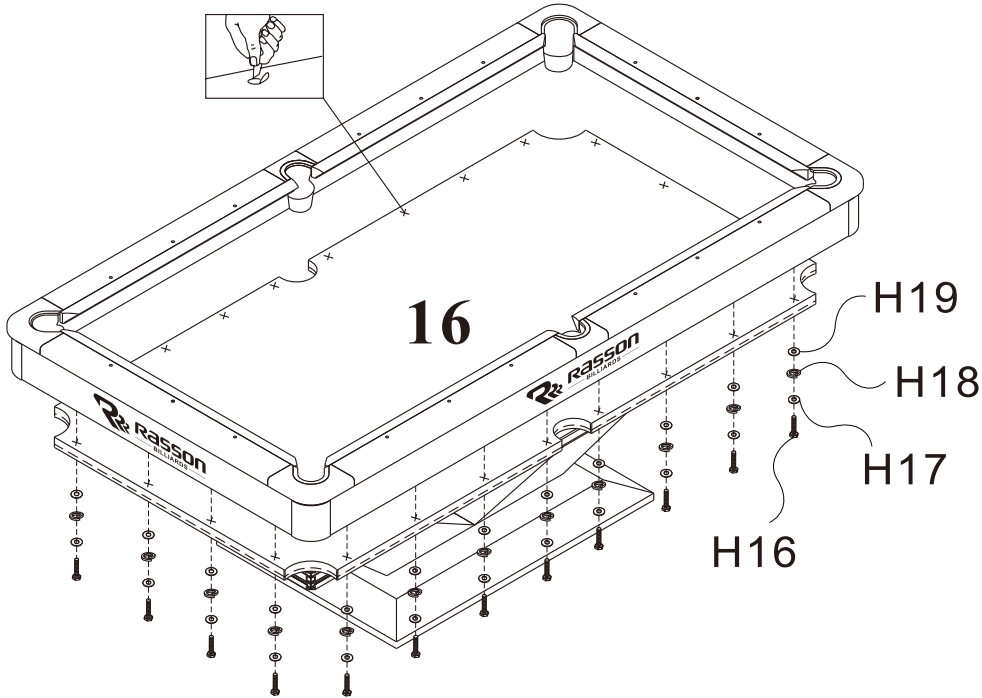


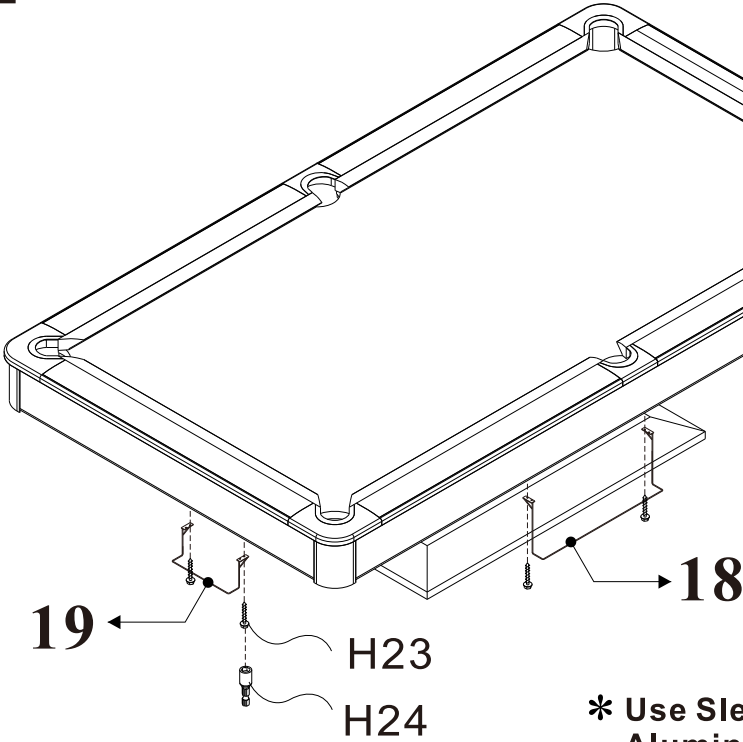
FIG.15

Cut holes in cloth at rail both locations.



*** Please MUST press down the pockets and make them underneath the slate to prevent balls from bouncing out.**

FINISH



*** Use Sleeve to attach the Screw to Aluminum Alloy beam through Holder.**