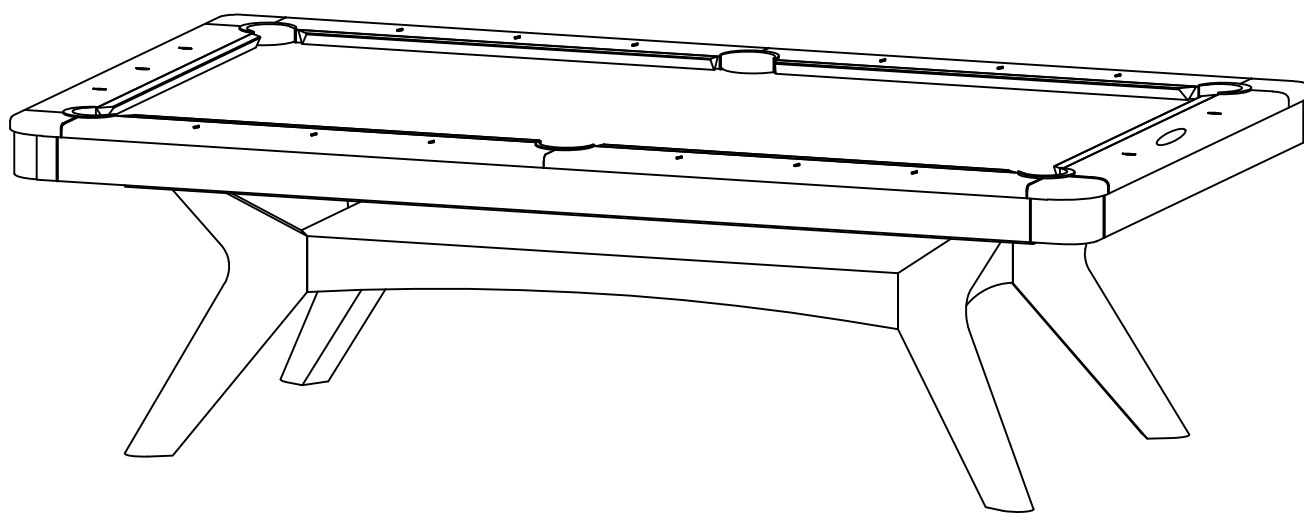


IMP 29-410-L  
IMP 29-410-P/B

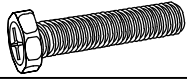


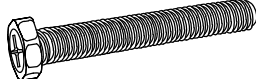
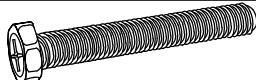
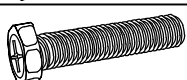


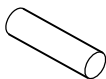



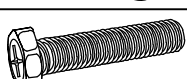
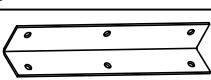


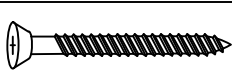
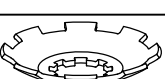





IMP 29-410-P/H  
IMP 29-410-R/B

# 7' BREVIK



## BREVIK TABLE ASSEMBLY INSTRUCTIONS

# REPLACEMENT PARTS LIST (HARDWARE)

Package	Item #	Sample	Description	Qty
LEG/ SHELF LEG	A		BOLT Ø3/8" X 2 1/2"	8
	B		WASHER Ø3/8" x Ø3/4" X T3/32"	8
LEG/ BEAM	B		WASHER Ø3/8" x Ø3/4" X T3/32"	32
	C		BOLT Ø3/8" X 4"	16
	D		BOLT Ø5/16" X 4"	8
	E		BOLT Ø5/16" X 2 3/4"	16
	F		WASHER Ø5/16" x Ø3/4" X T3/32"	24
	G		NUT Ø3/8"	16
	RAIL/BLIND	H		Dowel Ø10x30
I			BOLT Ø5/16"xL3"	6
J			NUT Ø5/16"	12
F			WASHER Ø5/16" x Ø3/4" X T3/32"	28
L			BOLT Ø5/16" X 1 1/2"	16
M			IRON 5" x 1" x1"	14
N			SCREW #8 x 1/2"	84
RAIL/POKET/SLATE	G		NUT Ø3/8"	18
	O		SCREW Ø1/4" x 2-1/2"	12
	P		DOME WASHER Ø3/8"	18
	Q		WASHER Ø3/8"	18
	R		BOLT Ø3/8"xL3"	18
	S		CORNER POCKET	4
	T		CENTER POCKET	2
	U		NAIL #5 x 5/8	12

# REPLACEMENT PARTS LIST (HARDWARE)


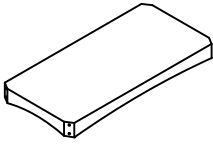
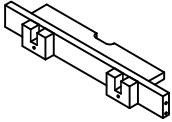
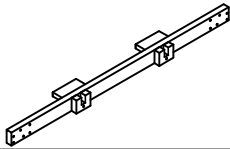
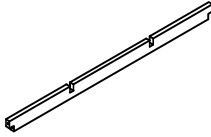
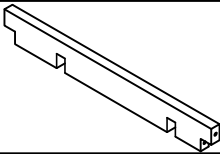
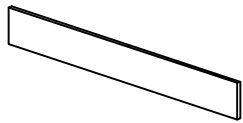

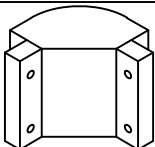
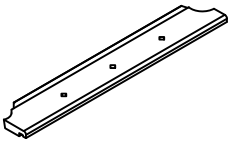
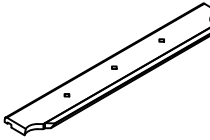
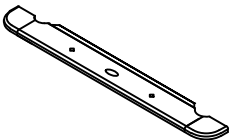
Package	Item #	Sample	Description	Qty
LEG	1		Leg (2 Left + 2 Right)	4
SHELF LEG	2		Shelf leg	1
BEAM	3		End beam	2
	4		Side beam	2
	5		Long beam	2
	6		Short Beam	2
Blind	7		End Blind	2
	8		Side Blind	2
	9		Corner Blind	4
Rail	10		Rail left side	2
	11		Rail right side	2
	12		End Rail	2

Fig.1

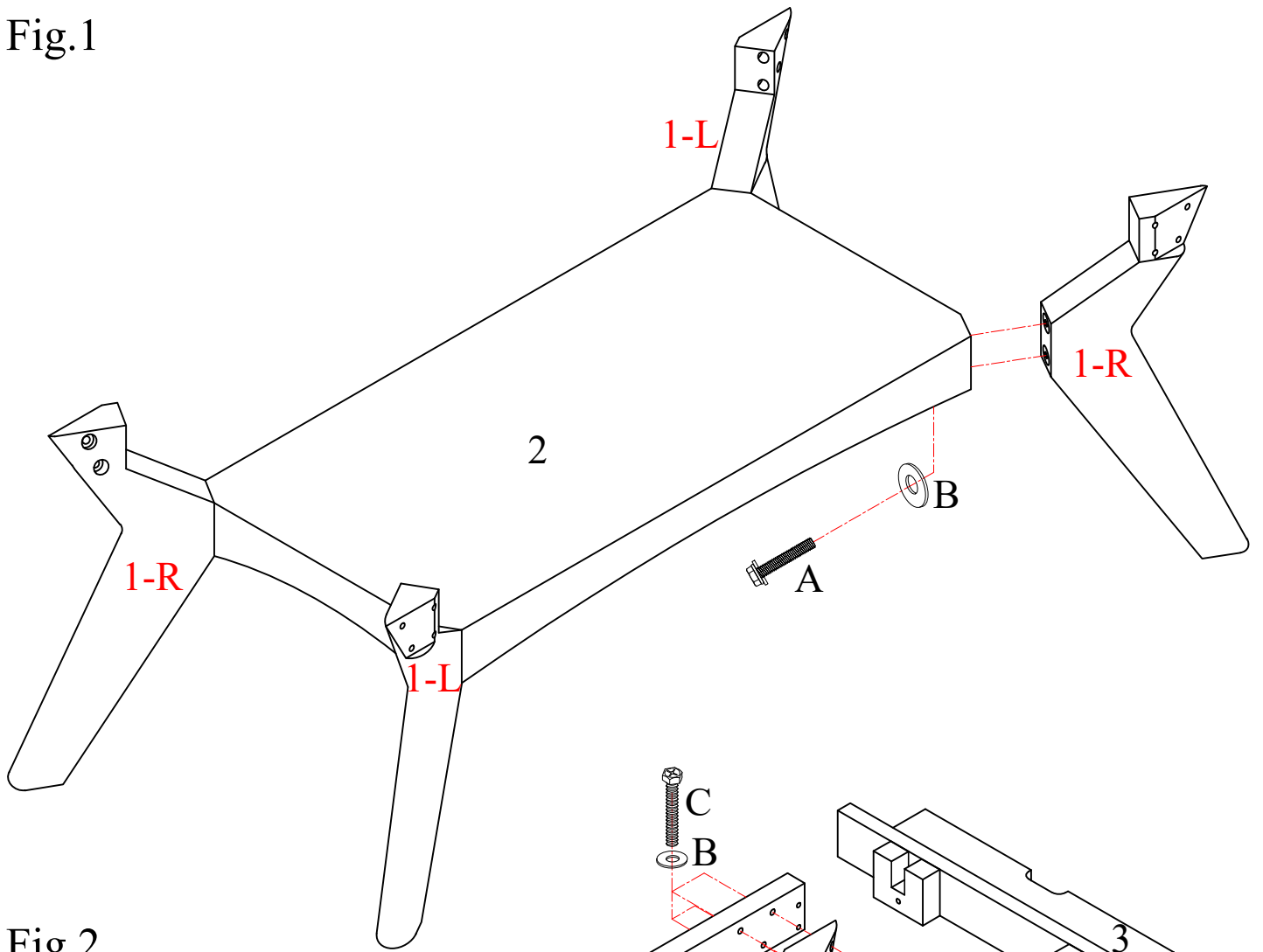


Fig.2

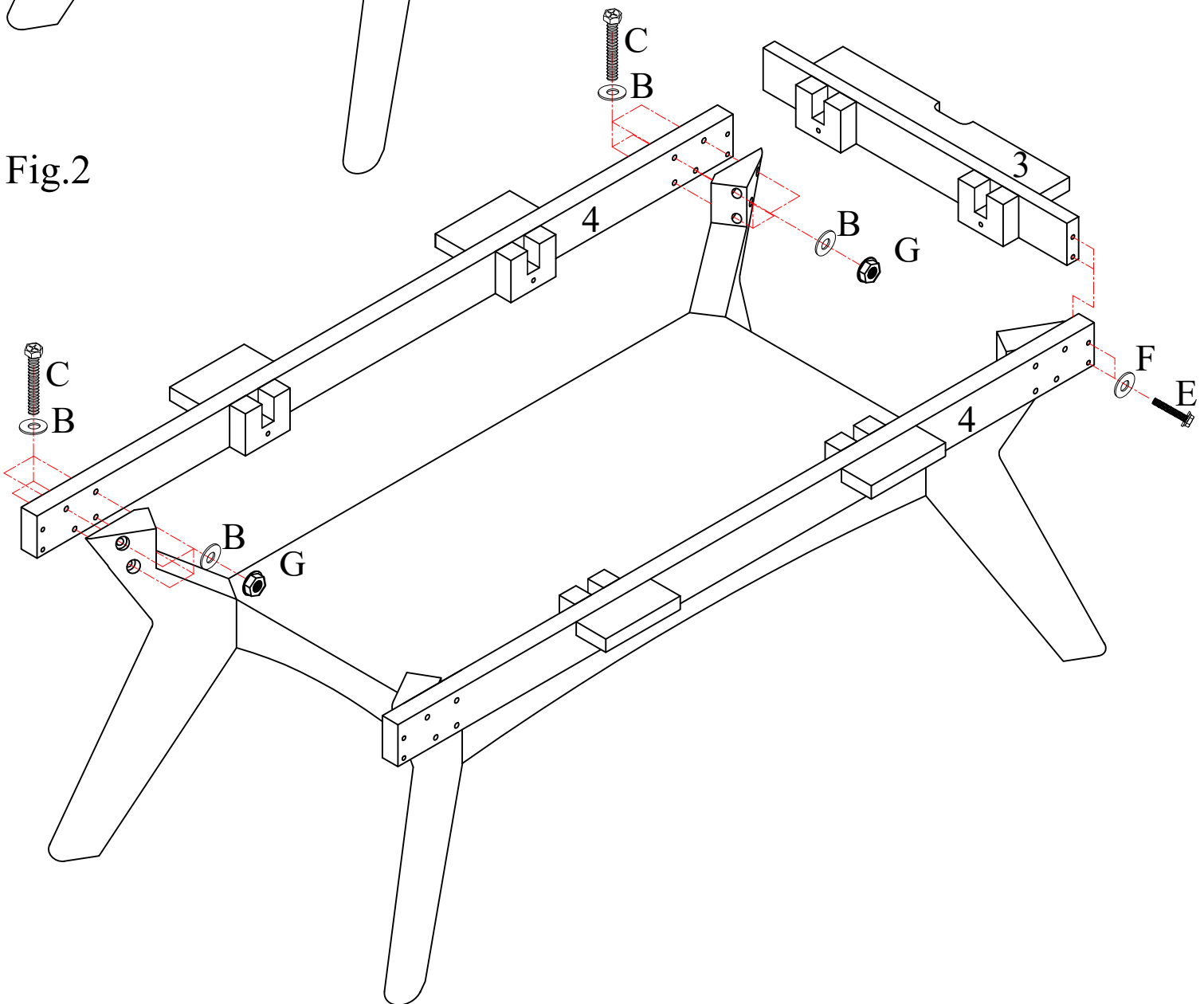


Fig.3

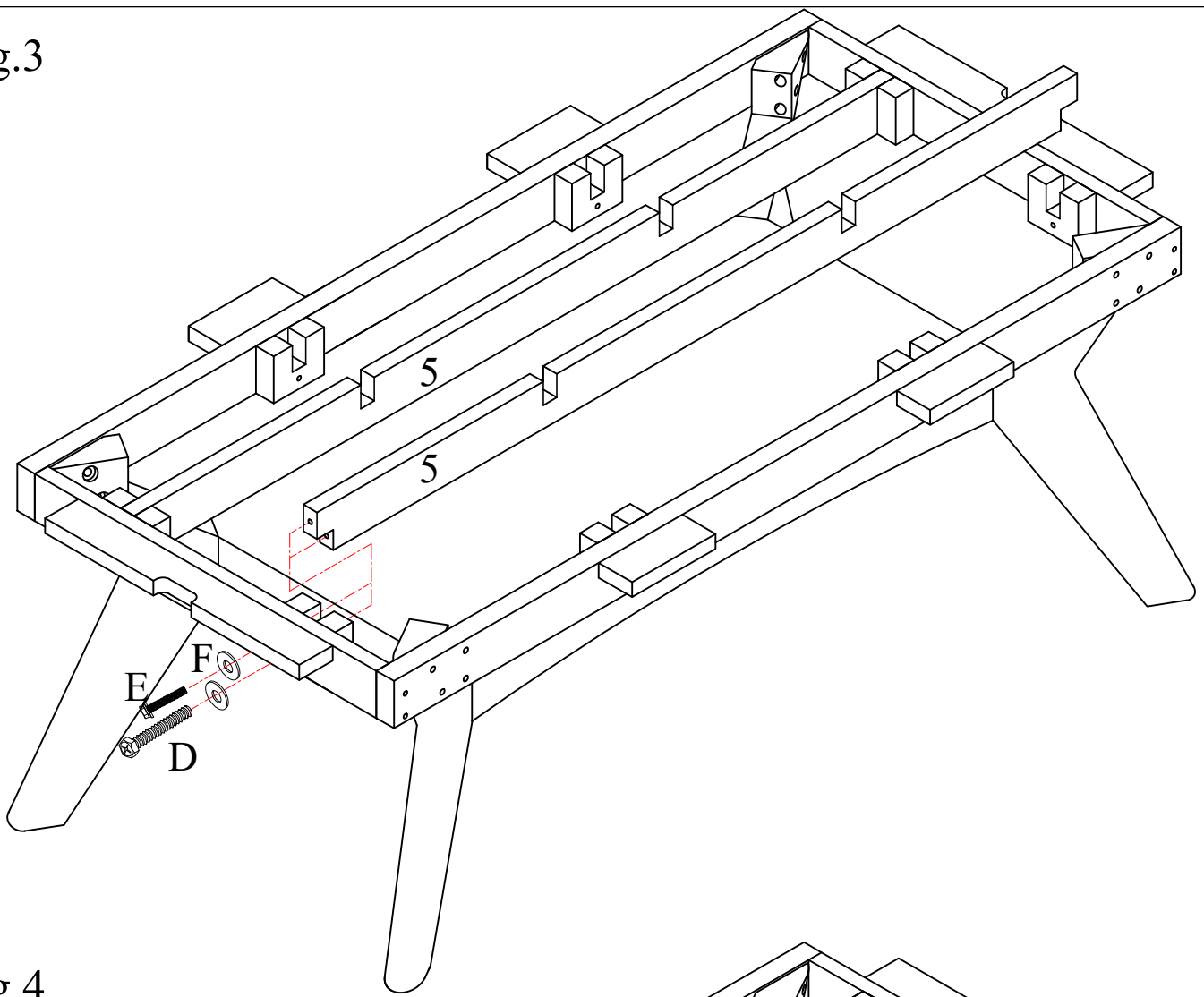


Fig.4

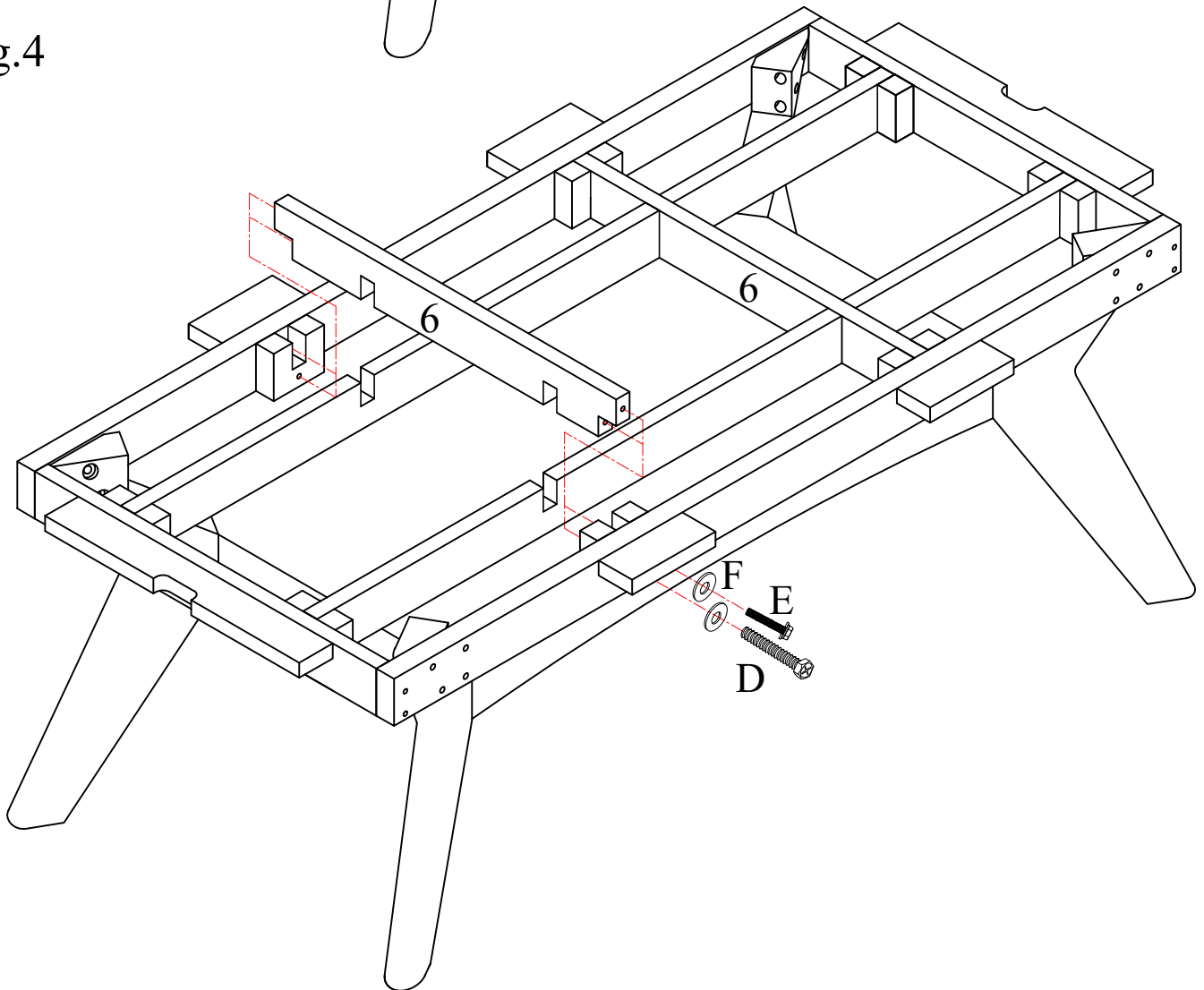


Fig.5

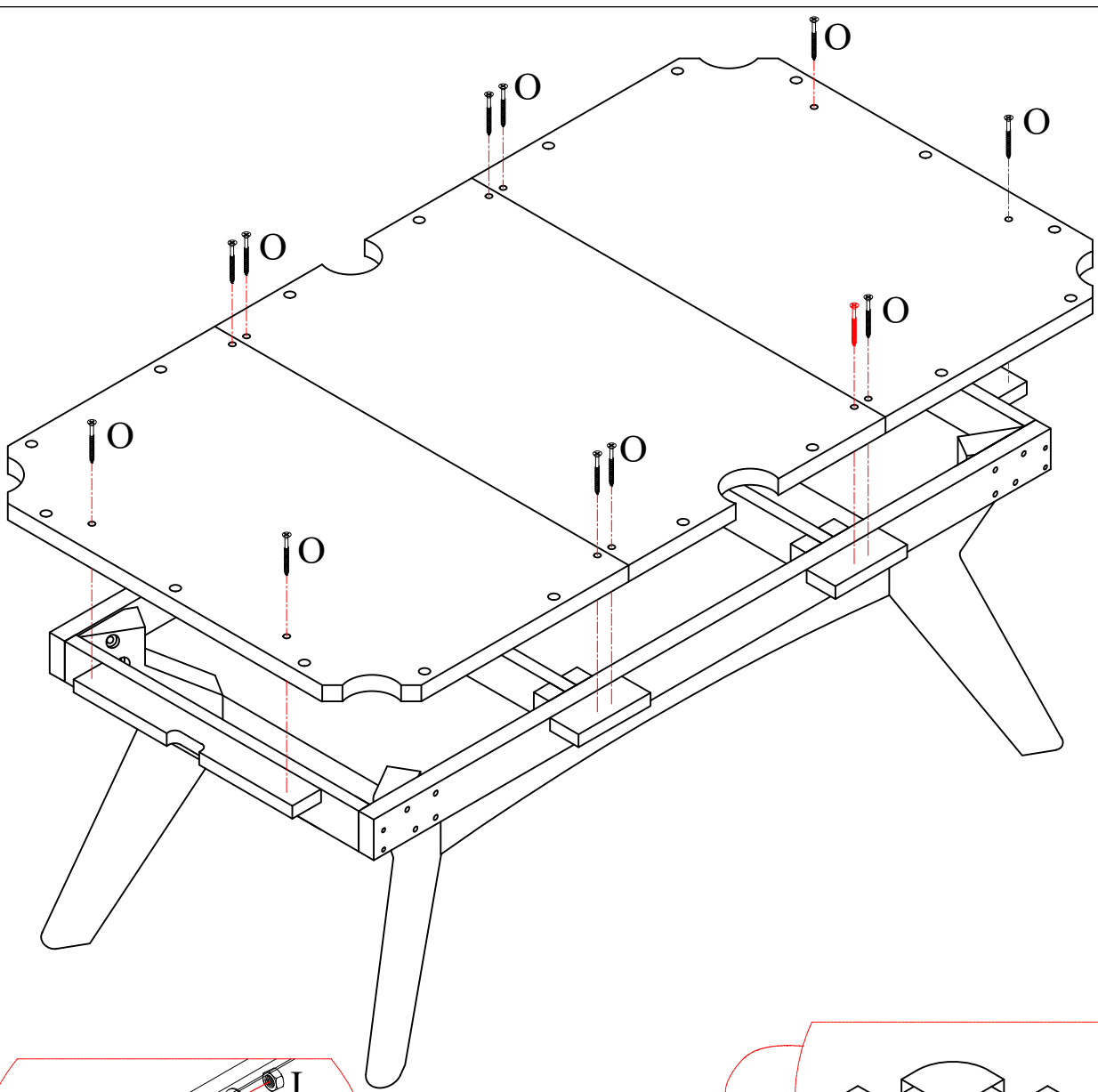


Fig.6

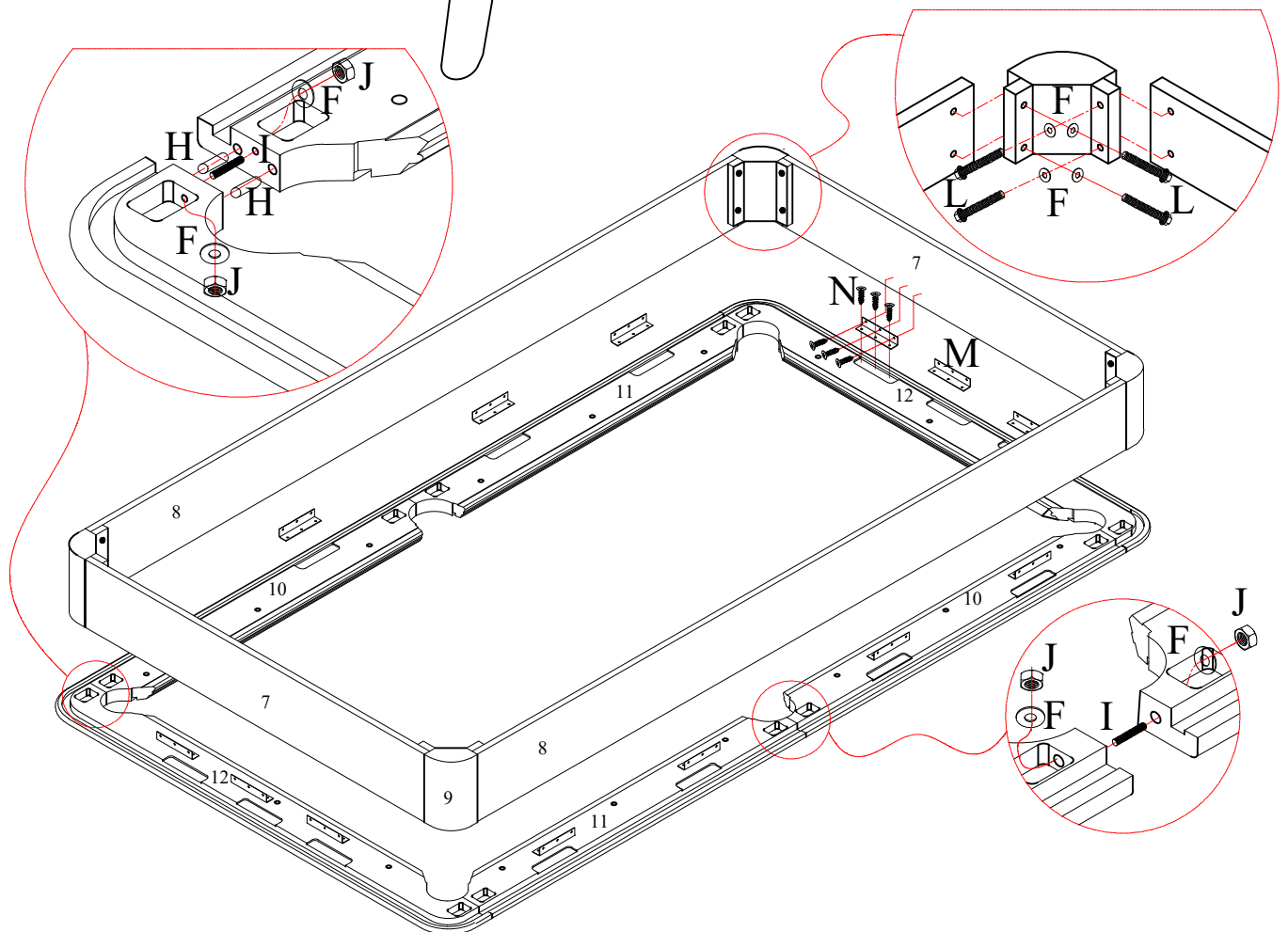


Fig.7

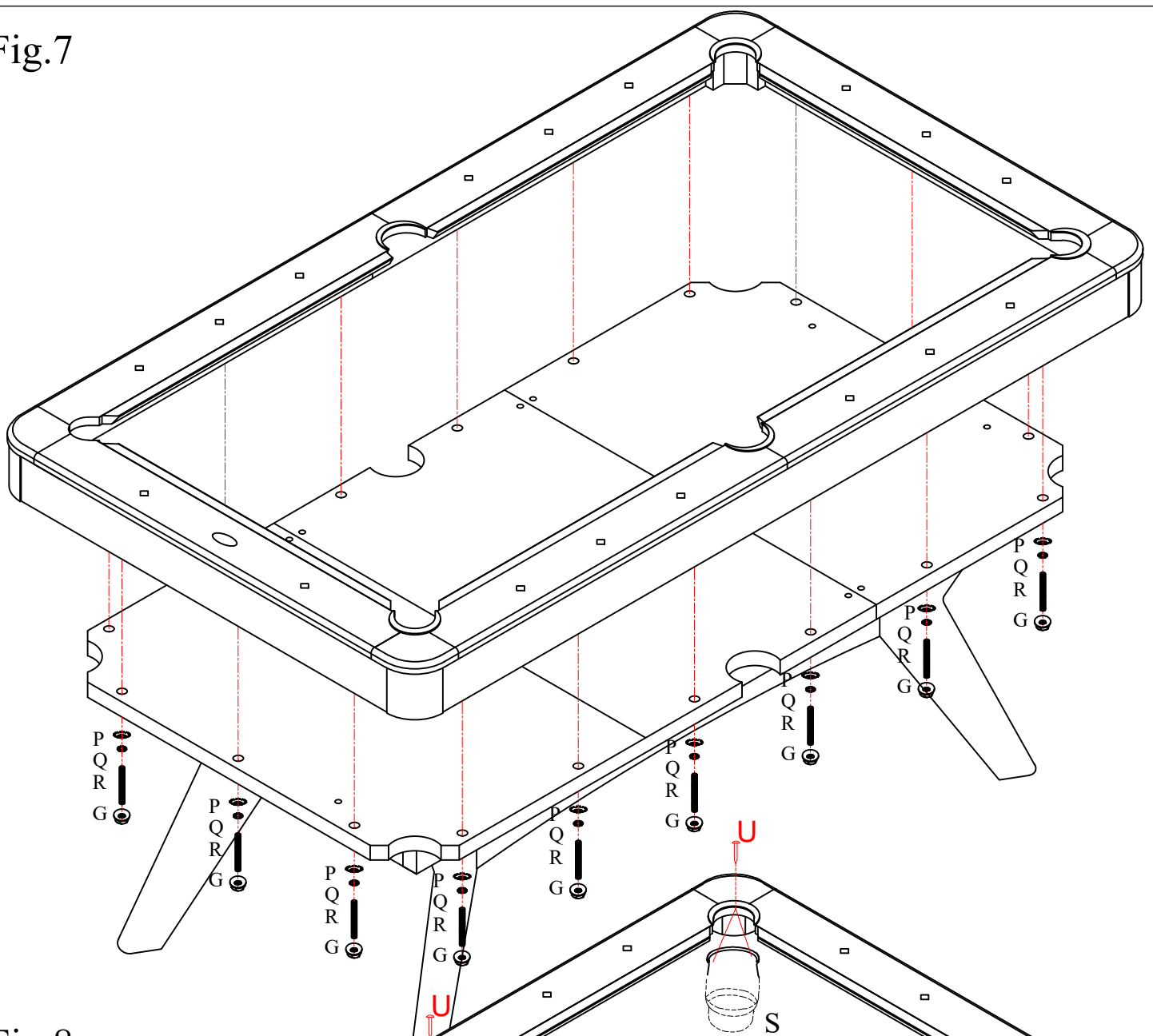


Fig.8

