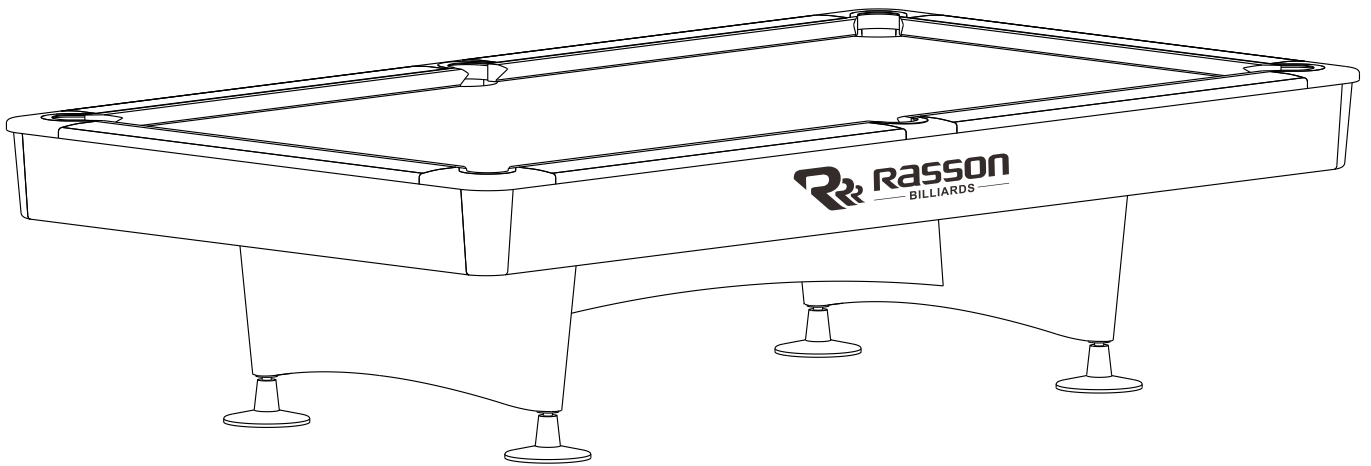

















# CHALLENGER<sup>+</sup>









## **BILLIARDS INSTRUCTION MANUAL**

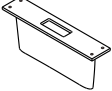
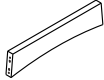



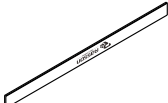

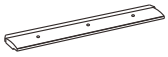

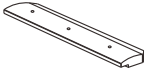
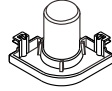


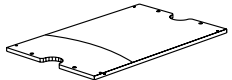
## REPLACEMENT PARTS LIST (HARDWARE)

PACKAGE	ITEM #	SAMPLE	DESCRIPTION	QTY.
LEG/PAD	H1		LEG LEVELLER	4
	H2		HEX HEAD CROSS BOLT 3/8" x 2-3/8"(M10 x 60mm)	4
	H3		FLAT WASHER 3/8" I.D.	4
CABINET	H4		HEX HEAD CROSS BOLT 3/8" x 2-3/8"(M10 x 60mm)	8
	H5		FLAT WASHER 3/8" I.D.	16
	H6		HEX NUT 3/8" I.D.	8
RAIL/POCKET/FRAME/SLATE	H7		INNER HEX BOLT 1/4" X 1-3/4"(M6 X 45mm)	12
	H8		HEX HEAD CROSS BOLT 3/8" X 1-3/8"(M10 X 35mm)	12
	H9		FLAT WASHER 3/8" I.D.	12
	H10		HEX HEAD CROSS BOLT 5/16" X 1"(M8X25mm)	16
	H11		FLAT WASHER 5/16" I.D.	16
	H12		HEX HEAD CROSS BOLT 5/16" X 11/16"(M8 X 17mm)	24
	H13		FLAT WASHER 5/16" I.D.	24
	H14		HEX HEAD CROSS BOLT 3/8" X 2-3/8"(M10 X 60mm)	18
	H15		FLAT WASHER 3/8" I.D. (THICK)	18

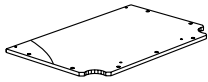




## REPLACEMENT PARTS LIST (HARDWARE)

PACKAGE	ITEM #	SAMPLE	DESCRIPTION	QTY.
	H16		SPRING LOCK WASHER 3/8" I.D.	18
	H17		FLAT WASHER 3/8" I.D.	18
	H18		PLASTIC BAYONET (WITHIN POCKET)	/
	H19		METAL BRACKET	12
	H20		SCREWS 8# X 1-1/16"(M4 X 27mm)	4
	H21		SLEEVE	1

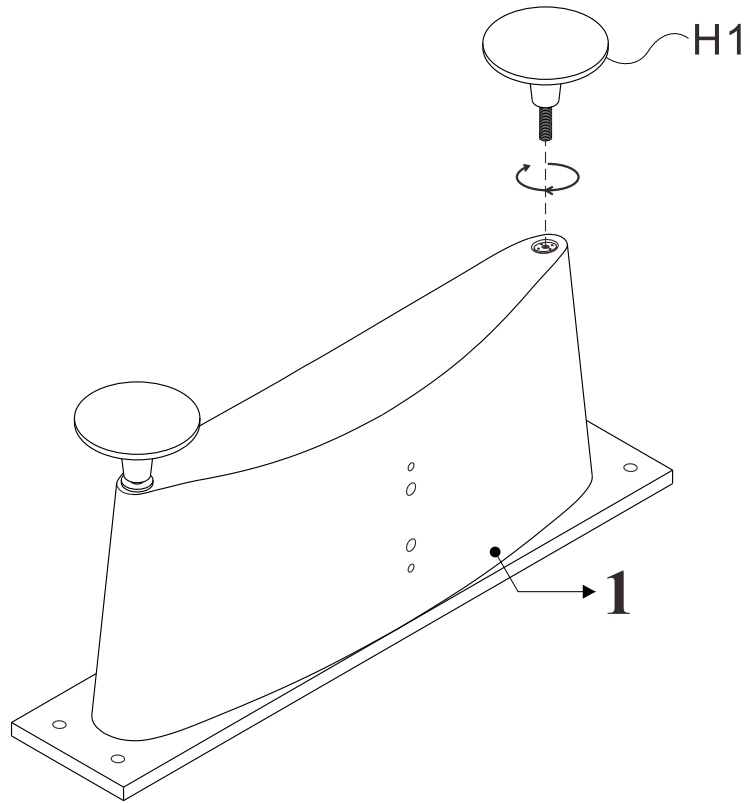
## REPLACEMENT PARTS LIST

PACKAGE	ITEM #	SAMPLE	DESCRIPTION	QTY.
LEG/PAD	1		LEG	2
	2		LEG BEAM	1
CABINET/FRAME	3		CABINET	1
	4		LEVELBOX PLUS	12
	5		END APRON	2
	6		SIDE APRON	2
	7		APRON CORNER	4
TOP RAIL	8		TOP RAIL LEFT SIDE	2
	9		TOP RAIL RIGHT SIDE	2
	10		TOP RAIL END	2
POCKET	11		CORNER POCKET	4
	12		SIDE POCKET	2
SLATE	13		SLATE (LEFT)	1
	14		SLATE (CENTER)	1

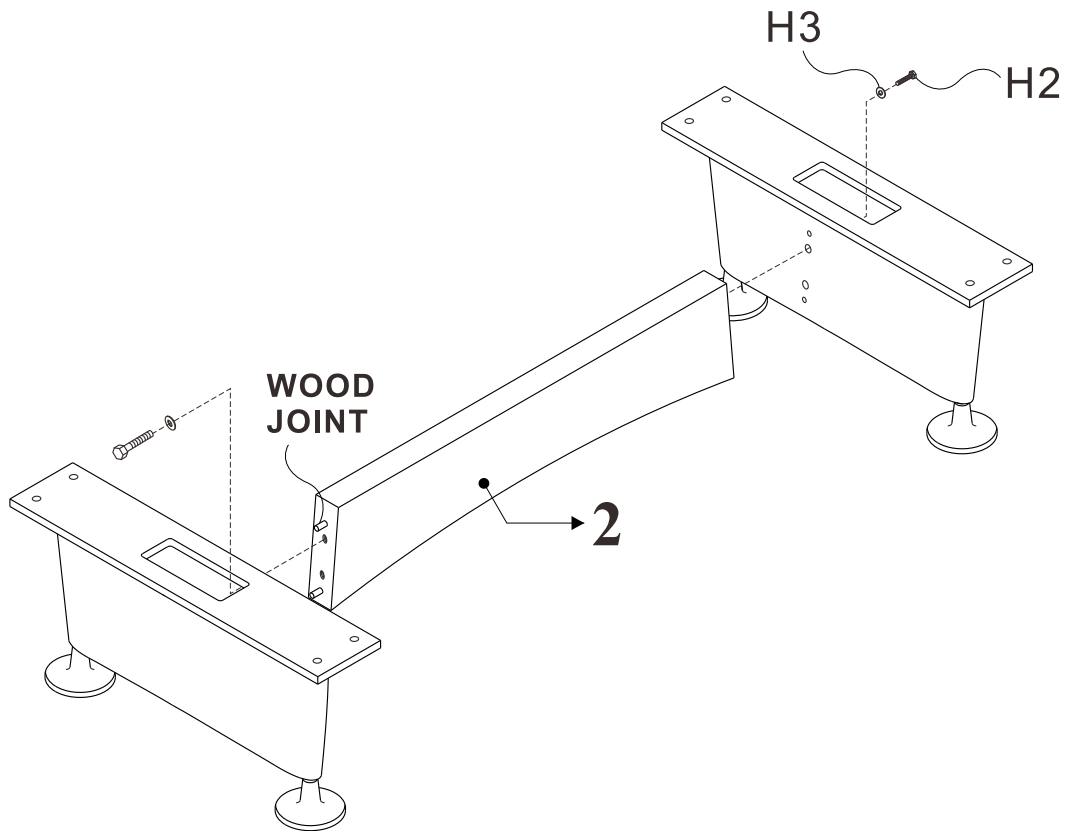
## REPLACEMENT PARTS LIST

PACKAGE	ITEM #	SAMPLE	DESCRIPTION	QTY.
	15		SLATE (RIGHT)	1
	16		CLOTH	1
	17		WOOD JOINT	4
	18		BRIDGE HOLDER	1
	19		TRIANGLE HOLDER	1

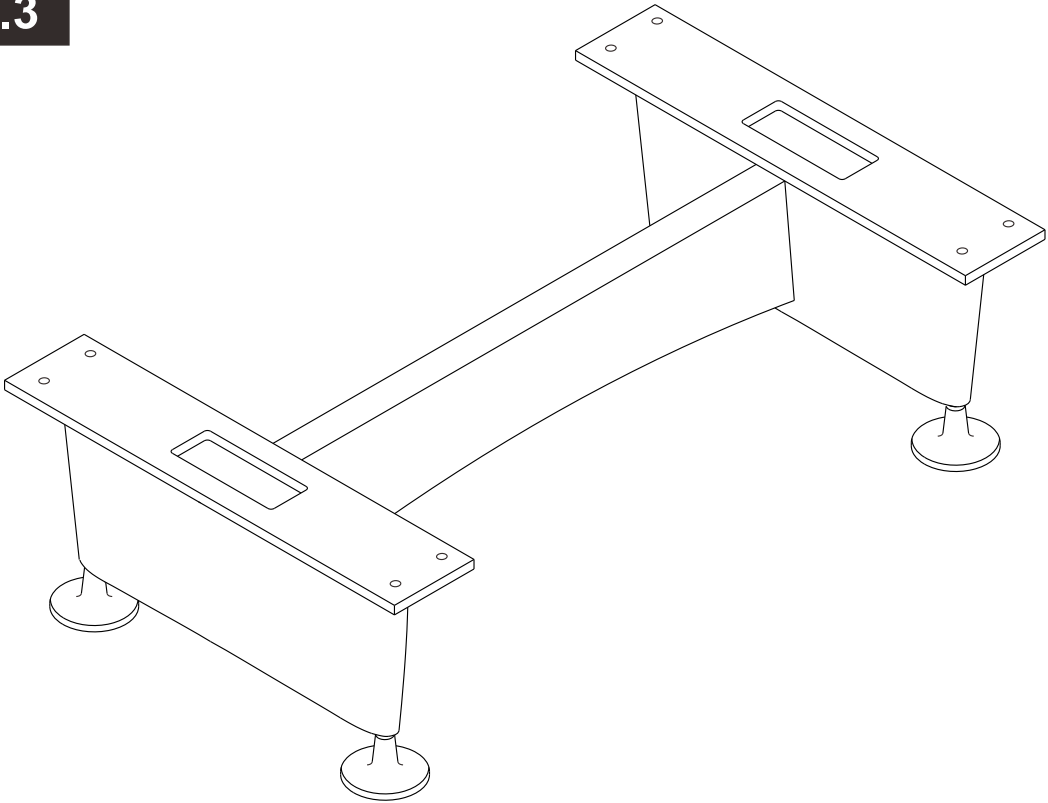
**FIG.1**



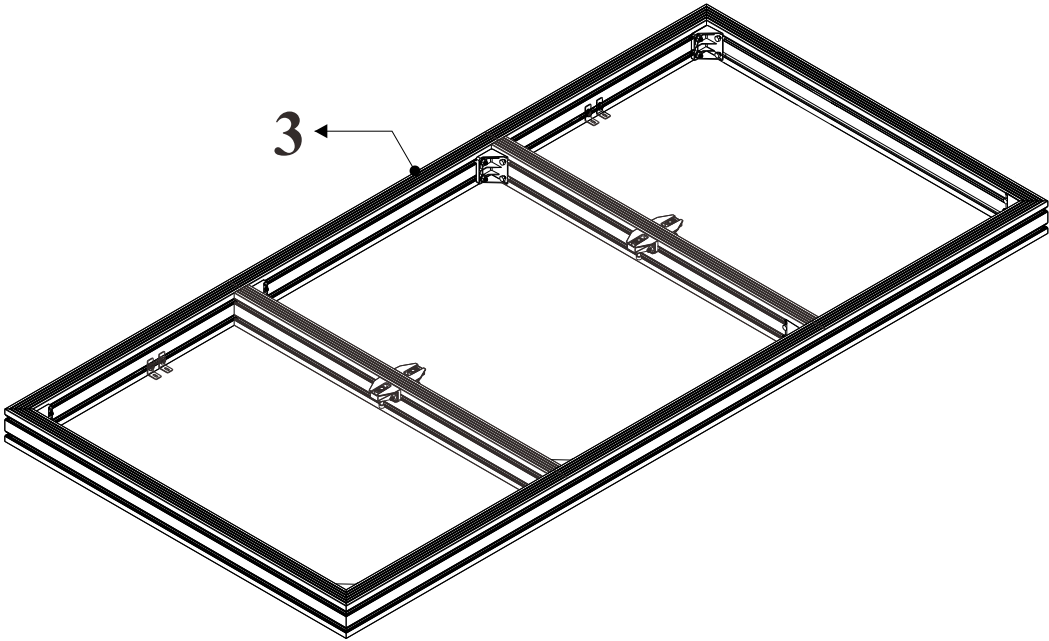
**FIG.2**



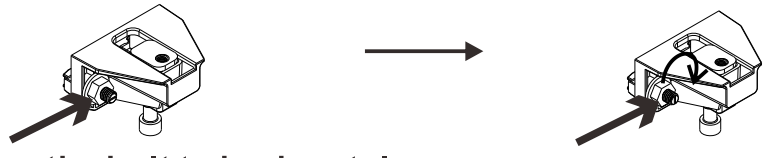
**FIG.3**



**FIG.4**



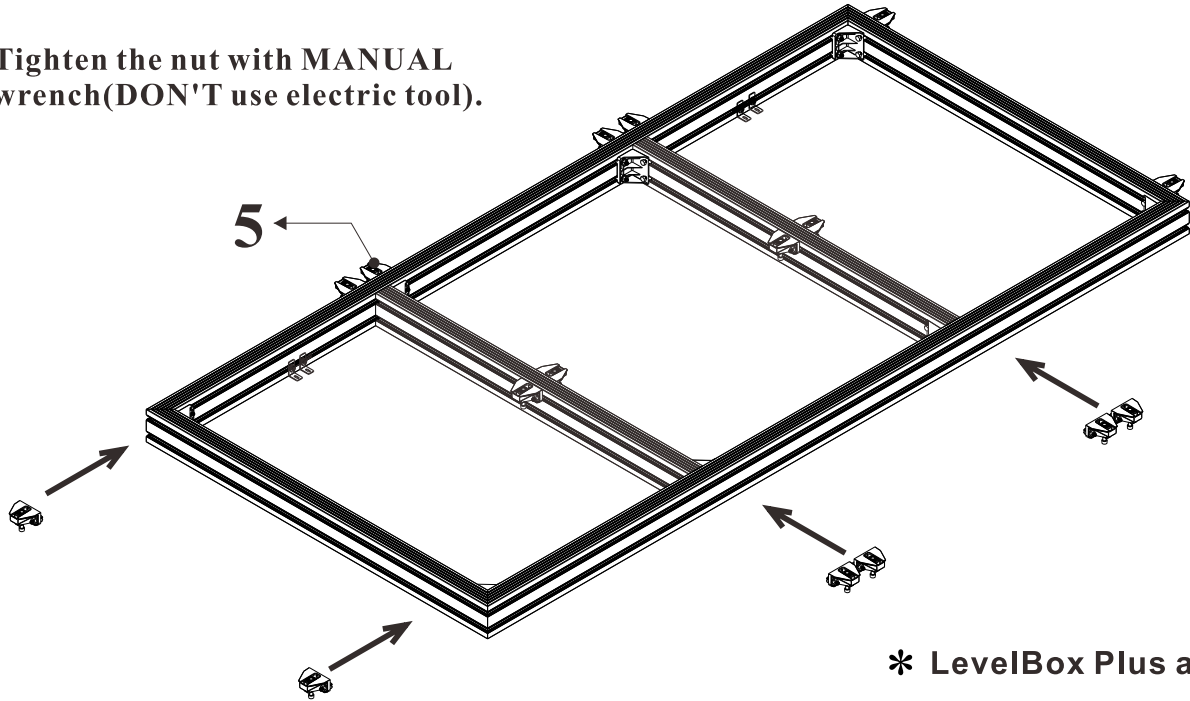
**FIG.5**



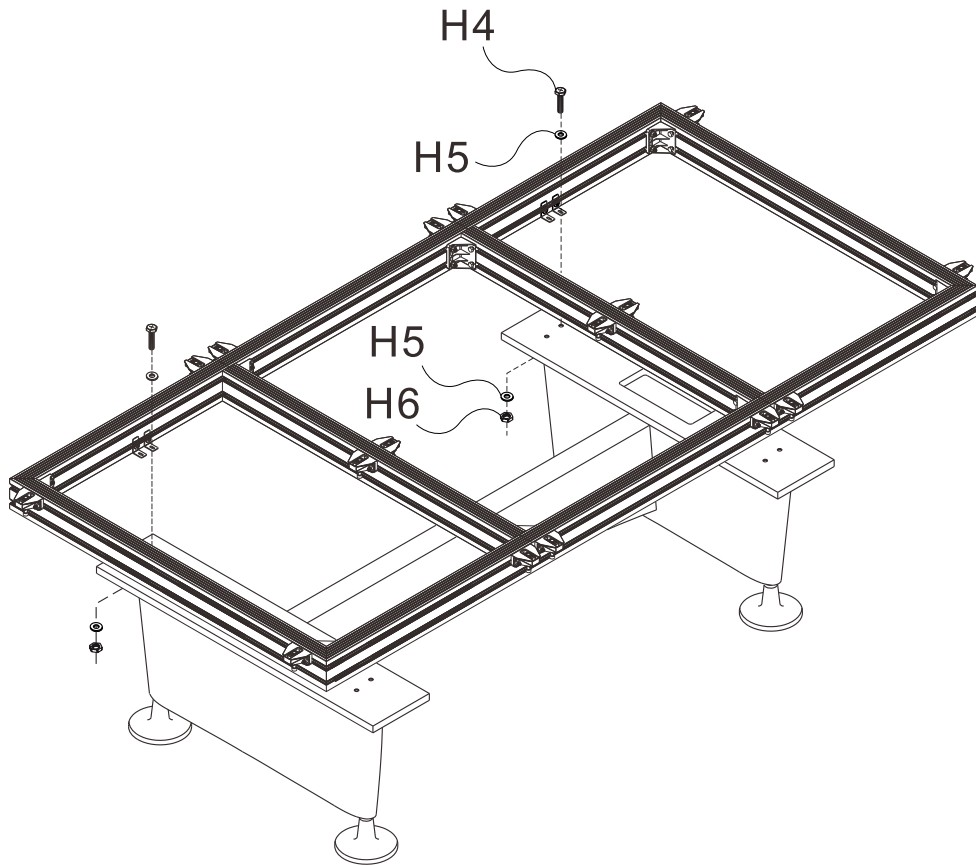
1. Turn the bolt to horizontal position, then insert 5 into alluminium alloy beam.

2. Turn the bolt to vertical position, then tighten the nut.

\* Tighten the nut with **MANUAL** wrench(DON'T use electric tool).

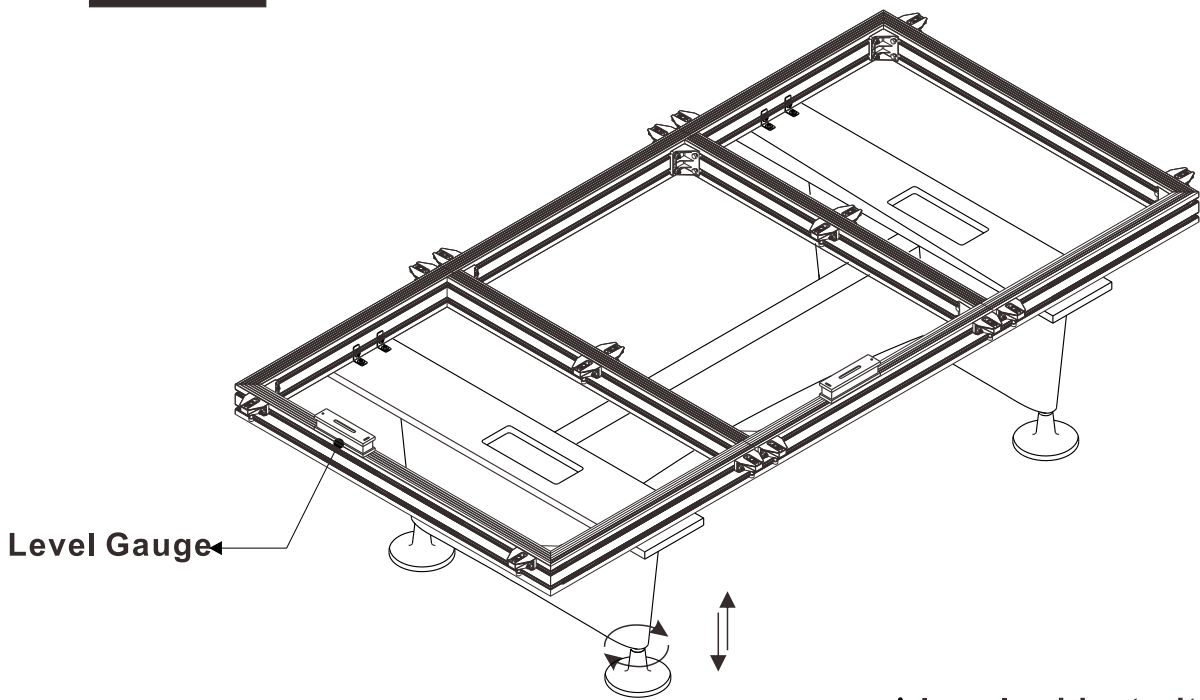


**FIG.6**



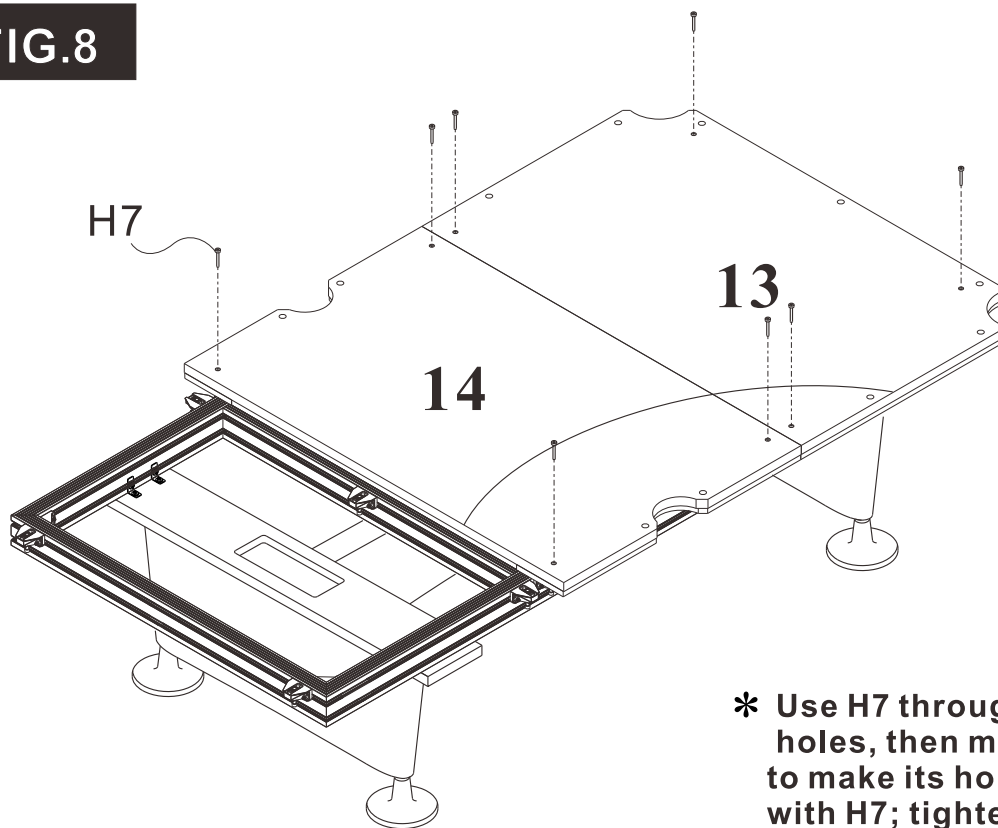


**FIG.7**



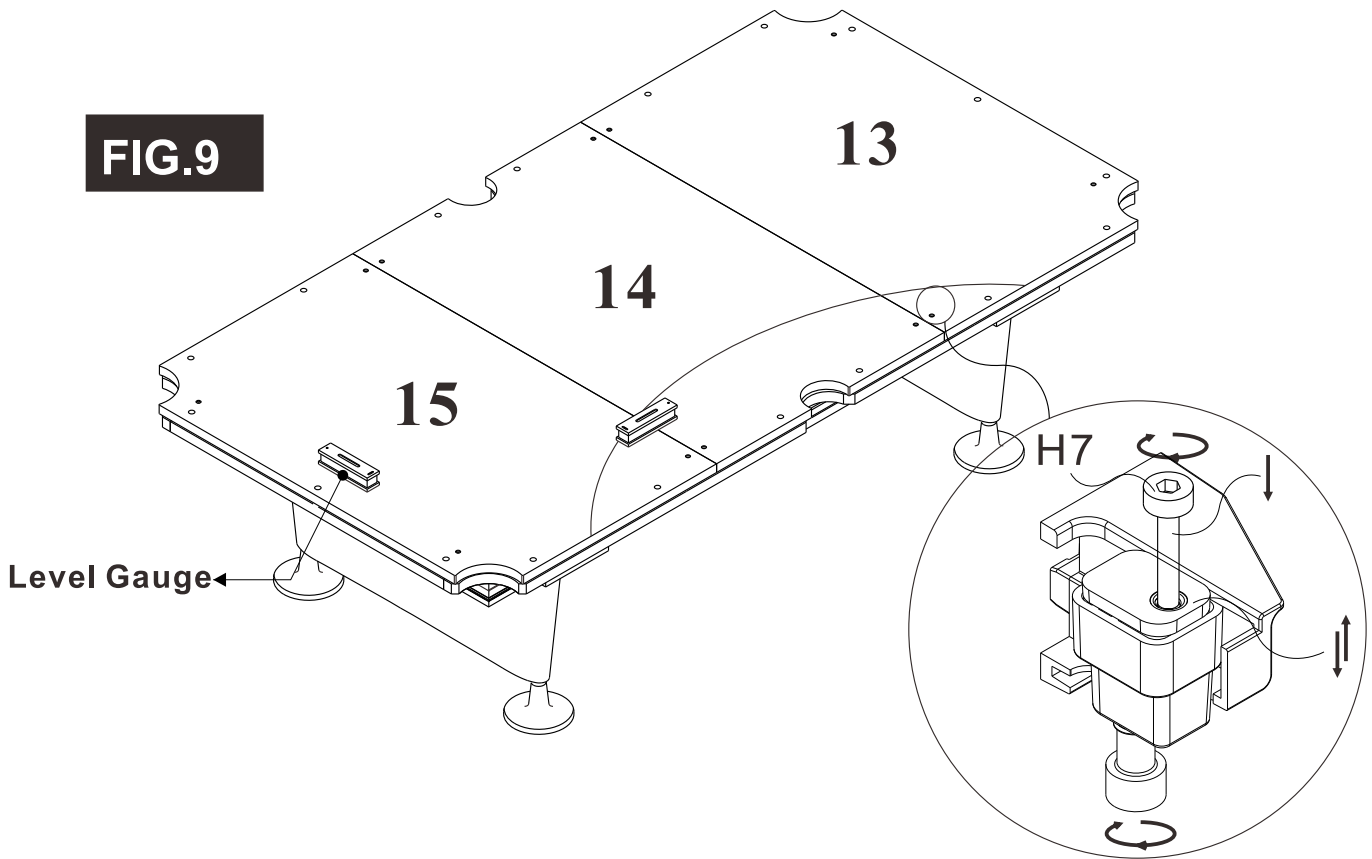
**\* Level cabinet with leg leveller.**

**FIG.8**



**\* Use H7 through slate stepped holes, then move 4 (Levelbox) to make its hole center line up with H7; tighten H7 after slate be leveled in next step.**

**FIG.9**

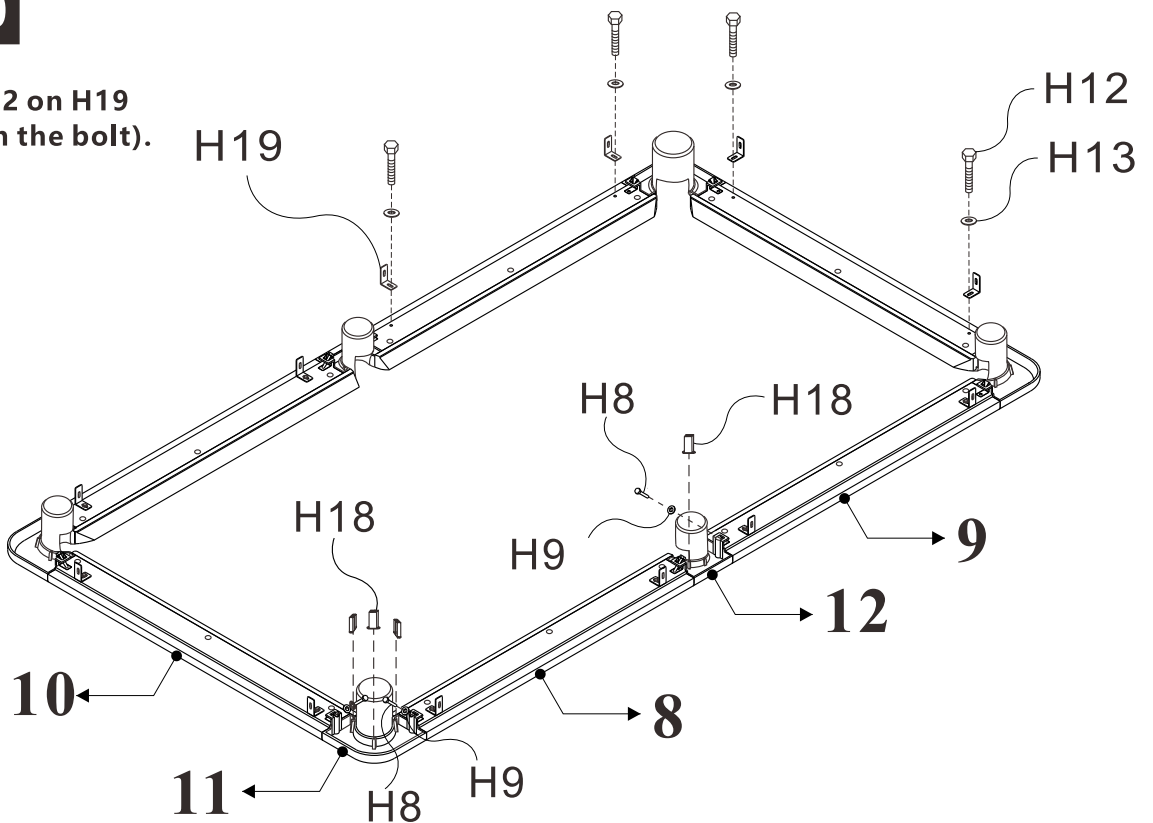


\* Level slate with 16 LevelBox adjusters.

\*Level slate through spinning hex screws to adjust slate height, then tighten H7 upon slate be leveled.

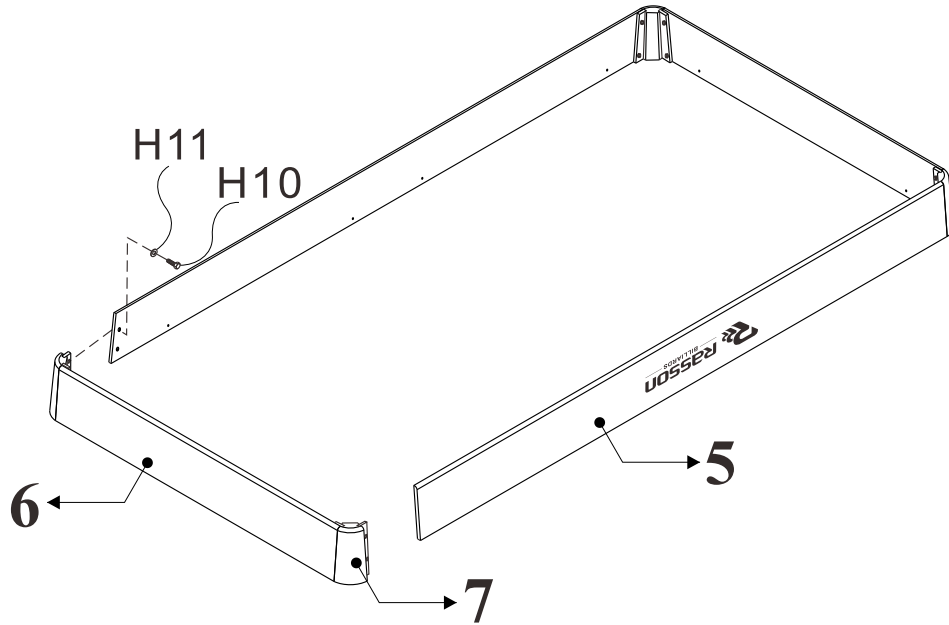
**FIG.10**

\* Attach the H12 on H19 (Don't tighten the bolt).



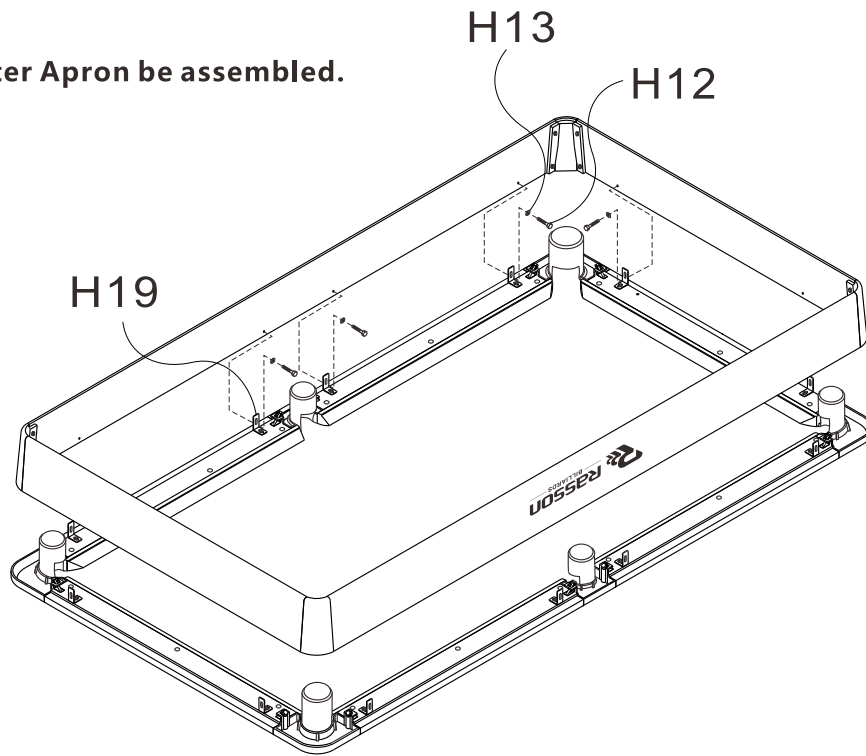
\* Tighten the pockets with H18.

**FIG.11**



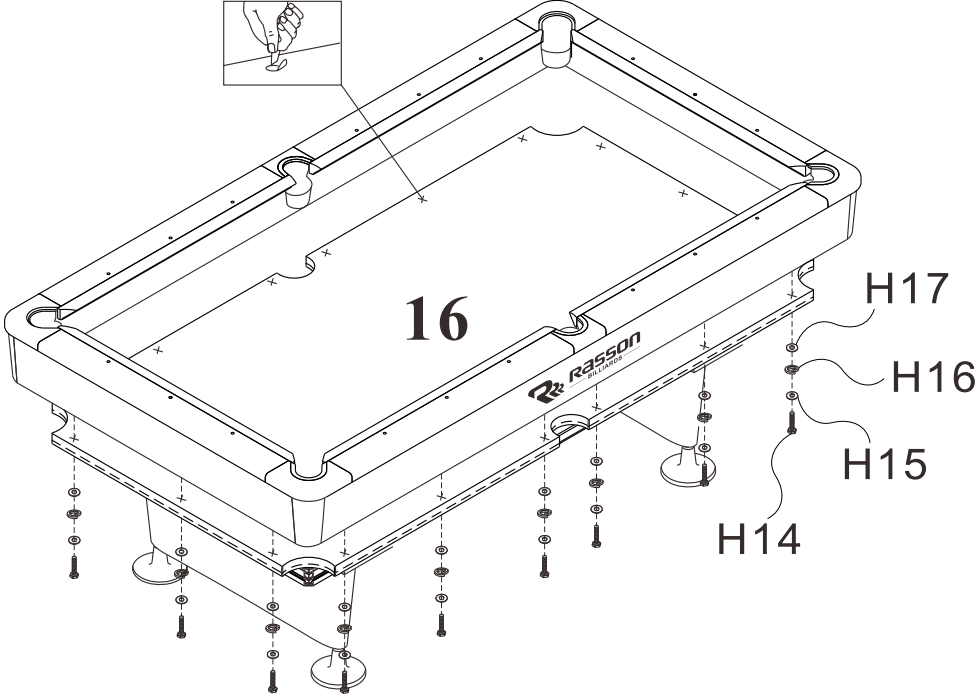
**FIG.12**

\* Tighten H12 after Apron be assembled.

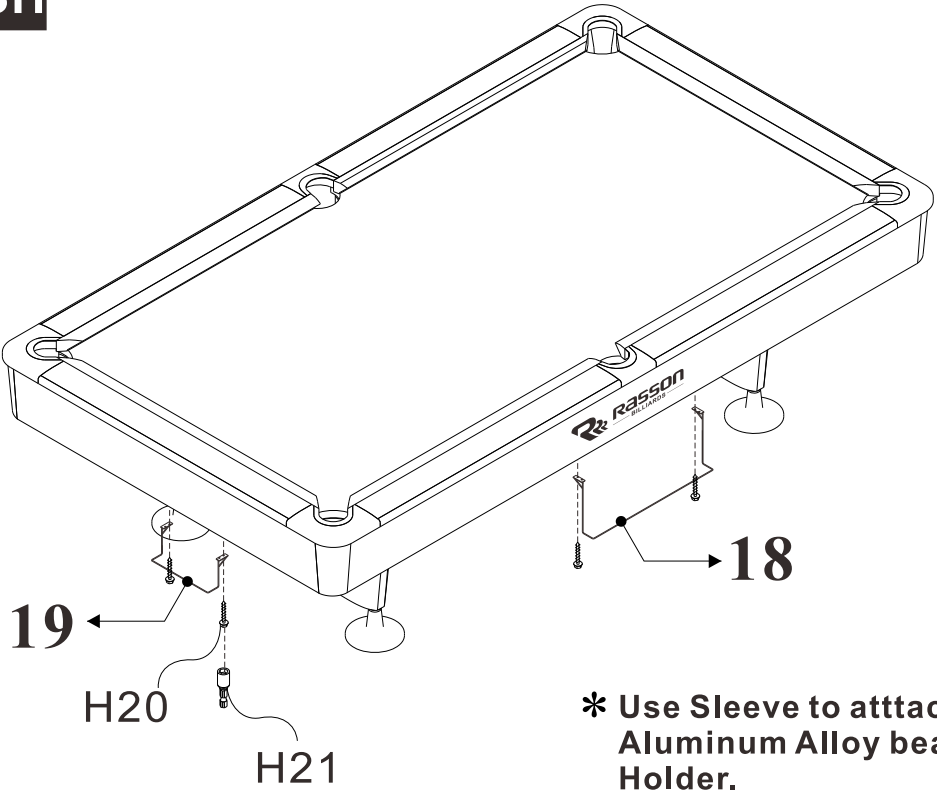


**FIG.13**

Cut holes in cloth at rail both locations.



**FINISH**



\* Use Sleeve to attach the Screw to Aluminum Alloy beam through Holder.