
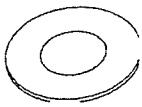




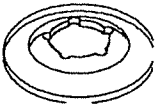
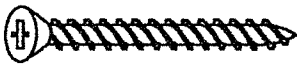
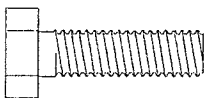





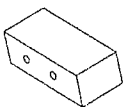
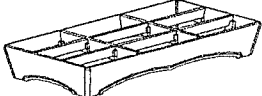






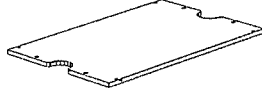

# UNIBODY

## INSTRUCTION MANUAL

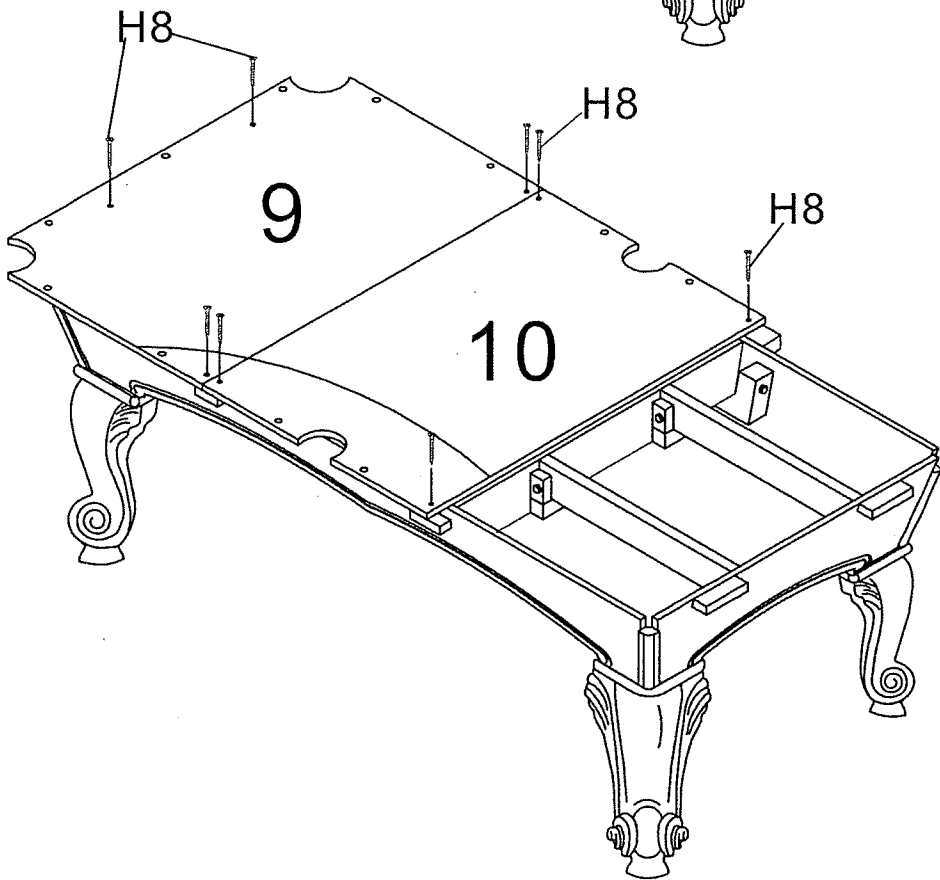
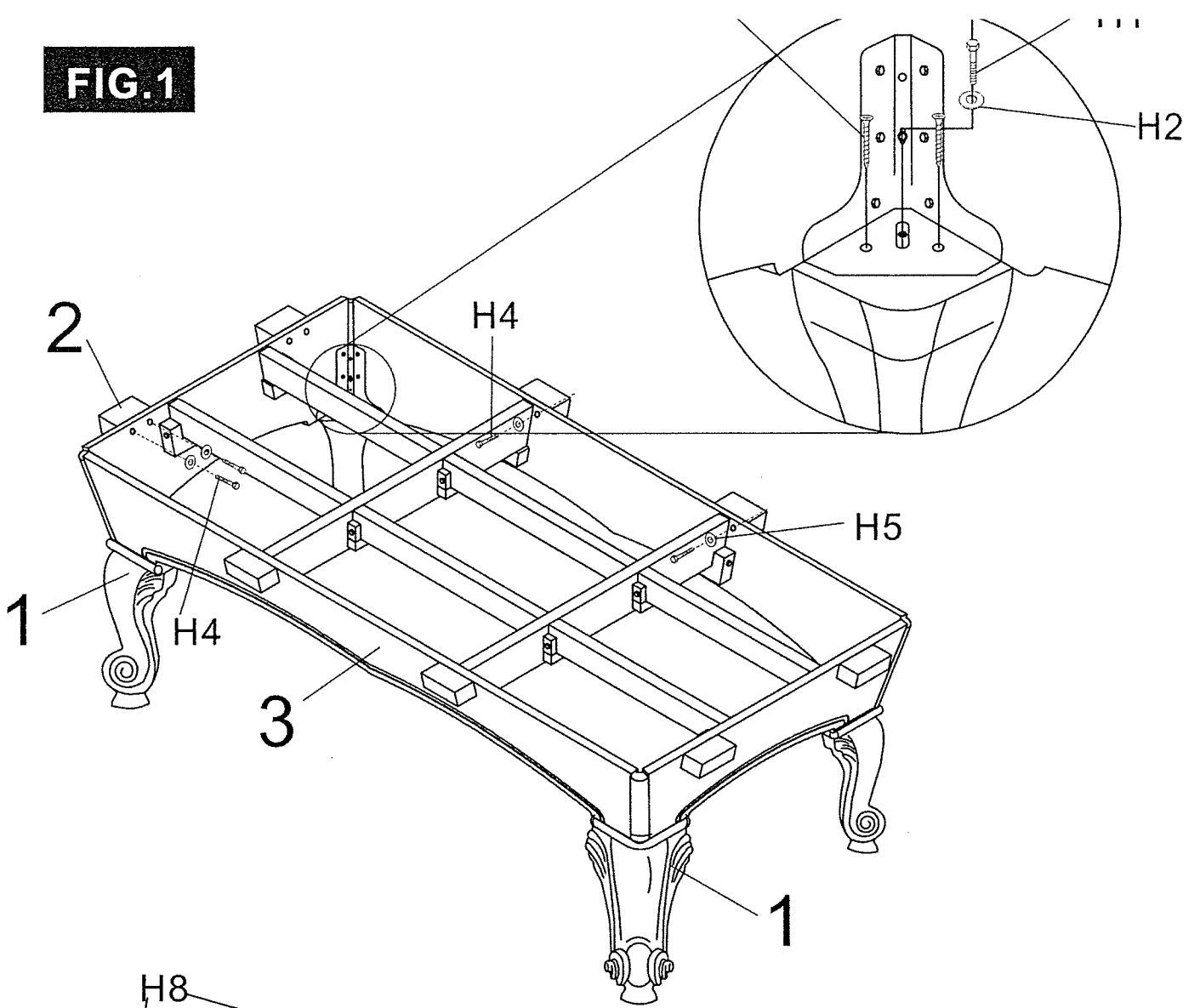
# REPLACEMENT PARTS LIST (HARDWARE)

PACKAGE	ITEM #	SAMPLE	DESCRIPTION	QTY.
LEG/PANEL	H1		HEX BOLT 3/8" x 2-1/2"	4
	H2		WASHER 3/8"ID x 1-1/4"OD	4
	H3		FLAT HEAD SCREW #8 x 1"	8
BEAM/BLOCK	H4		HEX BOLT 5/16" x 2"	16
	H5		WASHER 5/16"ID x 7/8"OD	16
RAIL/PACKET/SLATE	H6		HEX BOLT 3/8" x 2-1/2"	18
	H7		DOME WASHER 3/8"ID x 1-1/4"OD	18
	H8		FLAT HEAD SCREW #10 x 2-1/4"	12
	H9		HEX BOLT 5/16" x 1"	12
	H10		WASHER 5/16"ID x 7/8"OD	12
	H11		FLAT HEAD SCREW #6 x 7/16"	30

# REPLACEMENT PARTS LIST

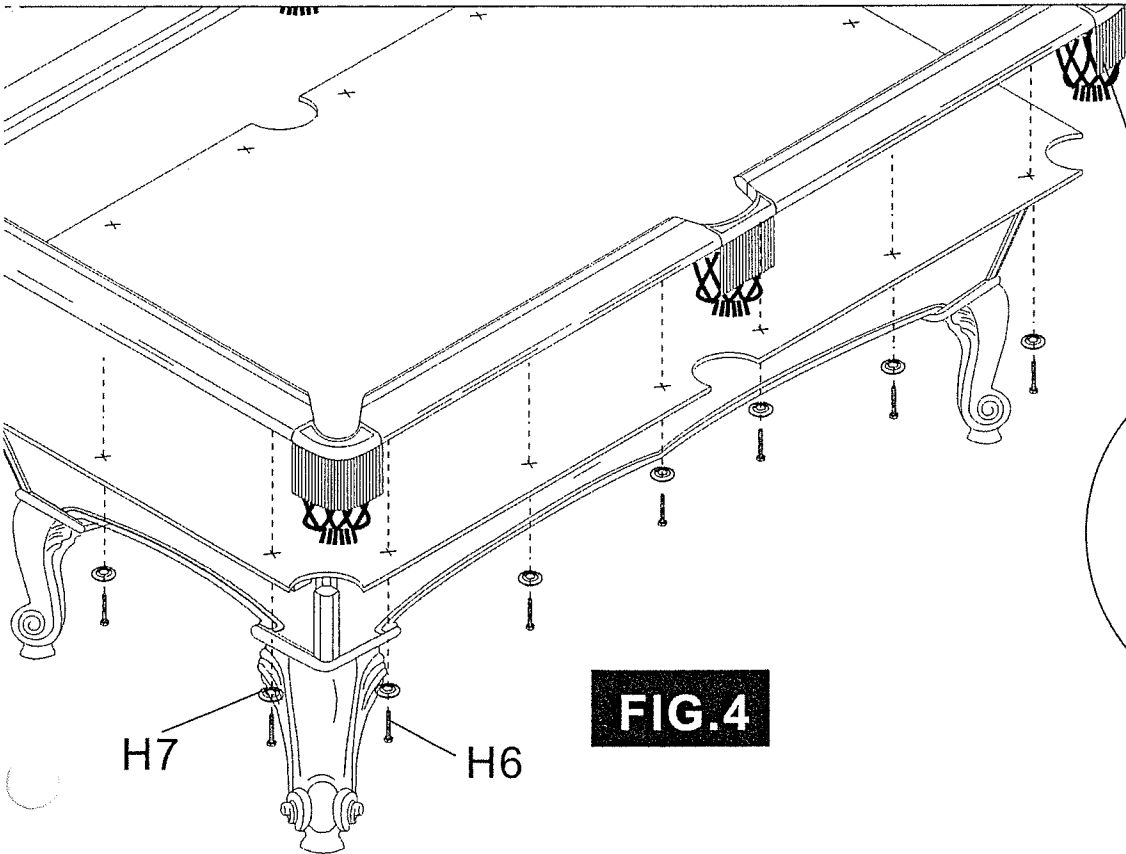
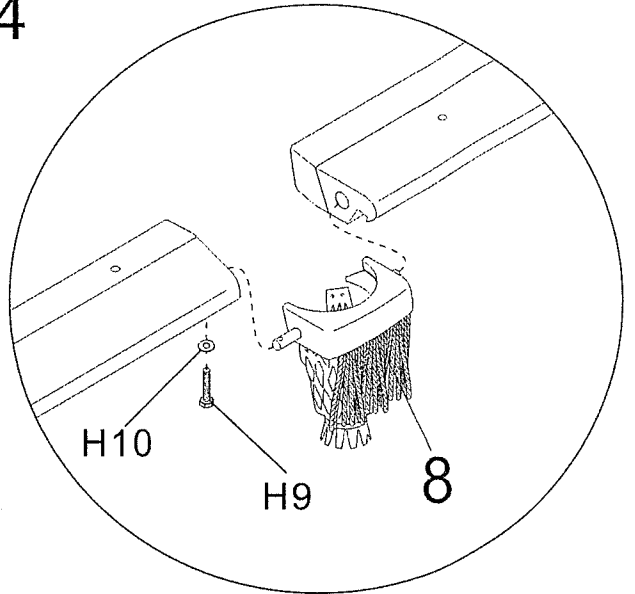
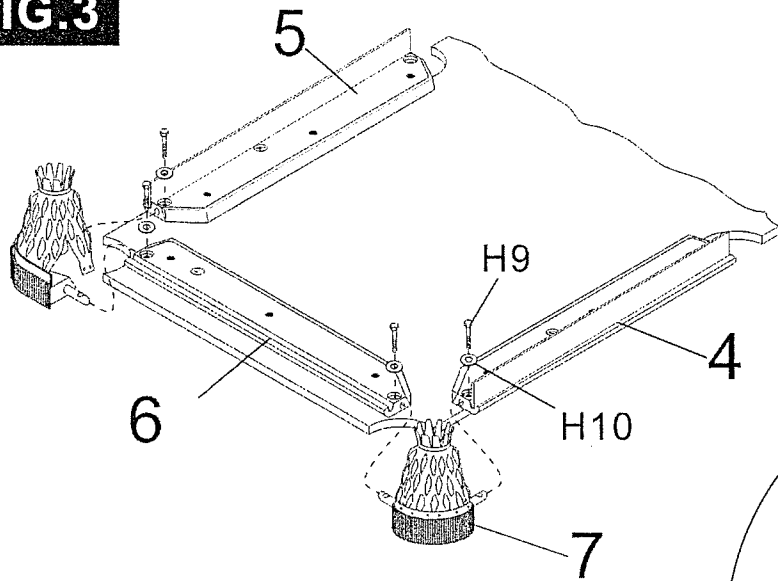
PACKAGE	ITEM #	SAMPLE	DESCRIPTION	QTY.	
TABLE	LEG	1		LEG	4
	BLOCK	2		WOODENBLOCK	8
		3		CABINET	1
	TOP RAIL	4		TOP RAIL LEFT SIDE	2
		5		TOP RAIL RIGHT SIDE	2
		6		TOP RAIL END	2
	POCKET	7		SIDE POCKET	2
		8		CONER POCKET	4
SLATE	9		SLATE (LEFT)	1	
	10		SLATE (CENTER)	1	
	11		SLATE (RIGTH)	1	

**FIG.1**

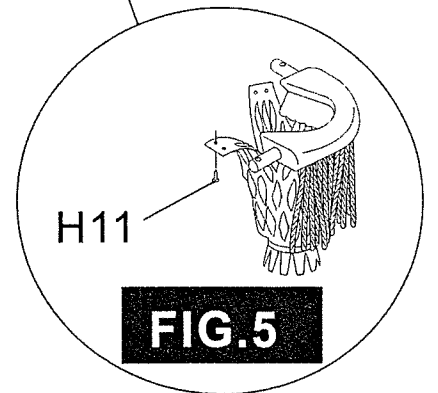


**FIG.2**

**FIG.3**



**FIG.4**



**FIG.5**