

IMP 29-2920597

IMP 29-2920598

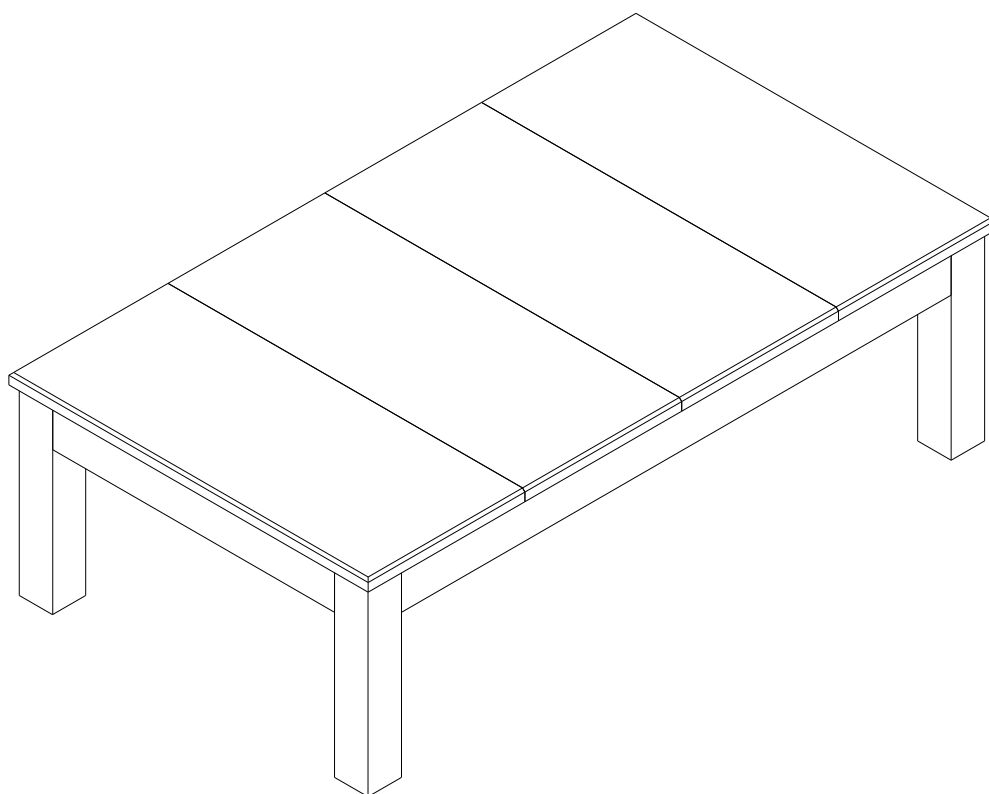
IMP 29-2920697

IMP 29-2920698

IMP 29-2920294

















IMP 29-2920295

7 & 8' PENELOPE II



PENELOPE II TABLE ASSEMBLY INSTRUCTIONS

REPLACEMENT PARTS LIST (HARDWARE)

PACKAGE	ITEM #	SAMPLE	DESCRIPTION	QTY.
LEG/PANEL	H1		STUD BOLT 3/8" X 4-5/16"(M10X110mm)	16
	H2		FLAT WASHER 3/8" I.D.	16
	H3		HEX NUT 3/8" I.D.	16
CABINET	H4		HEX HEAD CROSS BOLT 5/16" X 1"(M8X25mm)	16
	H5		FLAT WASHER 5/16" I.D.	16
	H6		HEX HEAD CROSS BOLT 3/8" X 3-1/8"(M10X80mm)	8
	H7		FLAT WASHER 3/8" I.D.	16
	H8		HEX NUT 3/8" I.D.	8
RAIL/POCKET/SLATE	H9		FLAT HEAD SCREW 1/4" X 2-3/4"(M6X70mm)	12
	H10		STUD BOLT 5/16" X 5-1/2"(M8X140mm)	2
	H11		STUD BOLT 5/16" X 3-1/2"(M8X88mm)	4
	H12		FLAT WASHER 5/16" I.D.	12
	H13		HEX NUT 5/16" I.D.	12
	H14		HEX HEAD CROSS BOLT 3/8" X 2-3/8"(M10X60mm)	18
	H15		DOME WASHER 3/8" I.D.	18
	H16		FLAT HEAD SCREW 5# X 1/2"(M3X12mm)	24

REPLACEMENT PARTS LIST


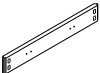
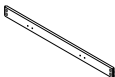
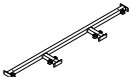
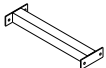

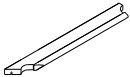
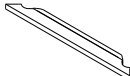



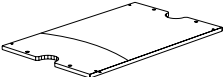
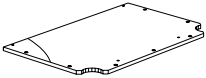

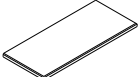
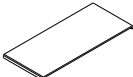
PACKAGE	ITEM #	SAMPLE	DESCRIPTION	QTY.
LEG	1		LEG	4
FRAME	2		END CABINET PANEL	2
	3		SIDE CABINET PANEL	2
BEAM	4		LONG SUPPORT BEAM	2
	5		SHORT SUPPORT BEAM	2
TOP RAIL	6		TOP RAIL LEFT SIDE	2
	7		TOP RAIL RIGHT SIDE	2
	8		TOP RAIL END	2
POCKET	9		SIDE POCKET	2
	10		CORNER POCKET	4
SLATE	11		SLATE (LEFT)	1
	12		SLATE (CENTER)	1
	13		SLATE (RIGHT)	1
	14		CLOTH	1
DINING TOP	15		END DINING TOP	2
	16		MIDDLE DINING TOP	2

FIG.1

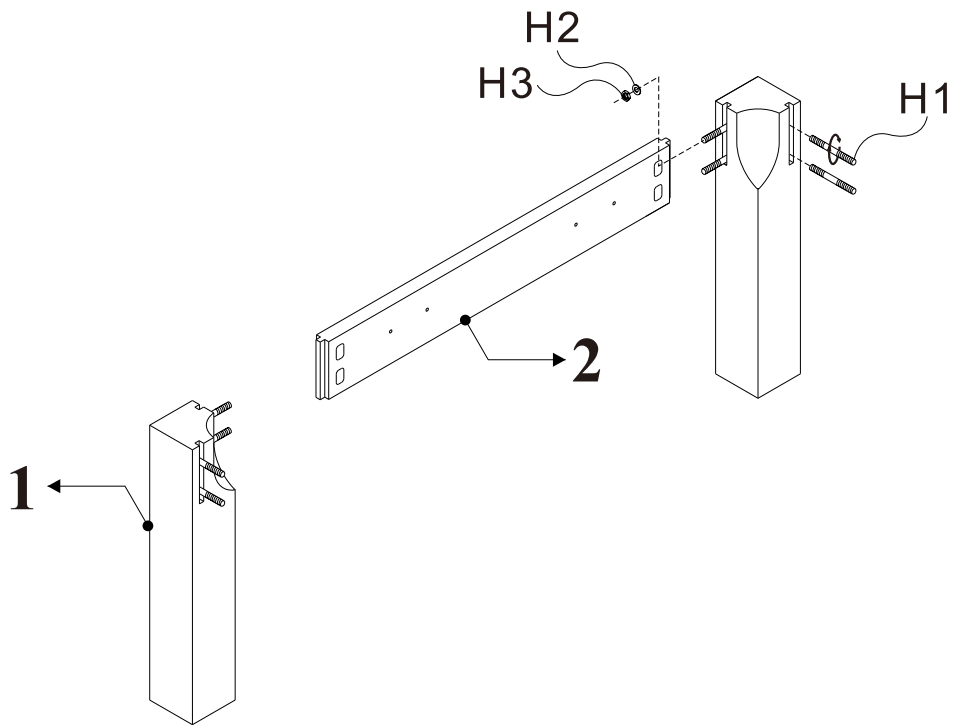


FIG.2

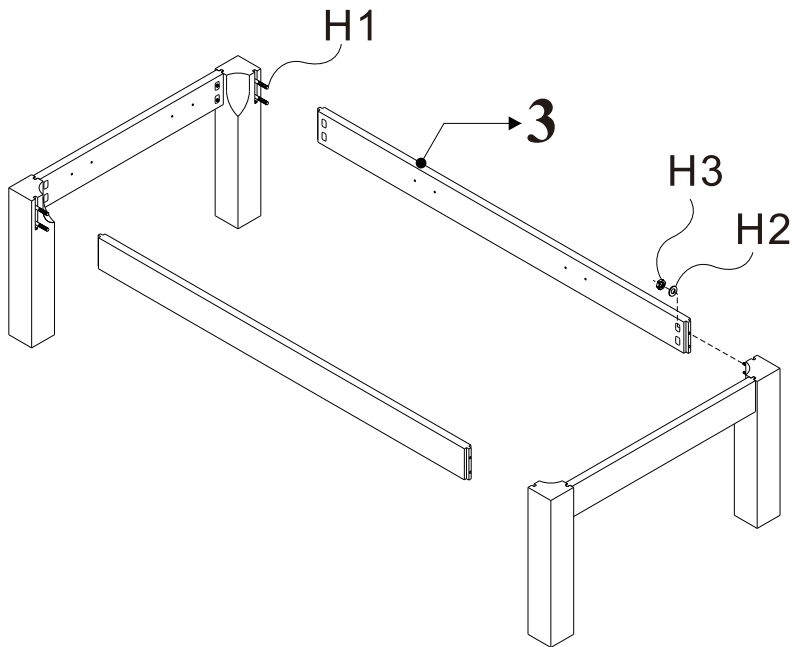


FIG.3

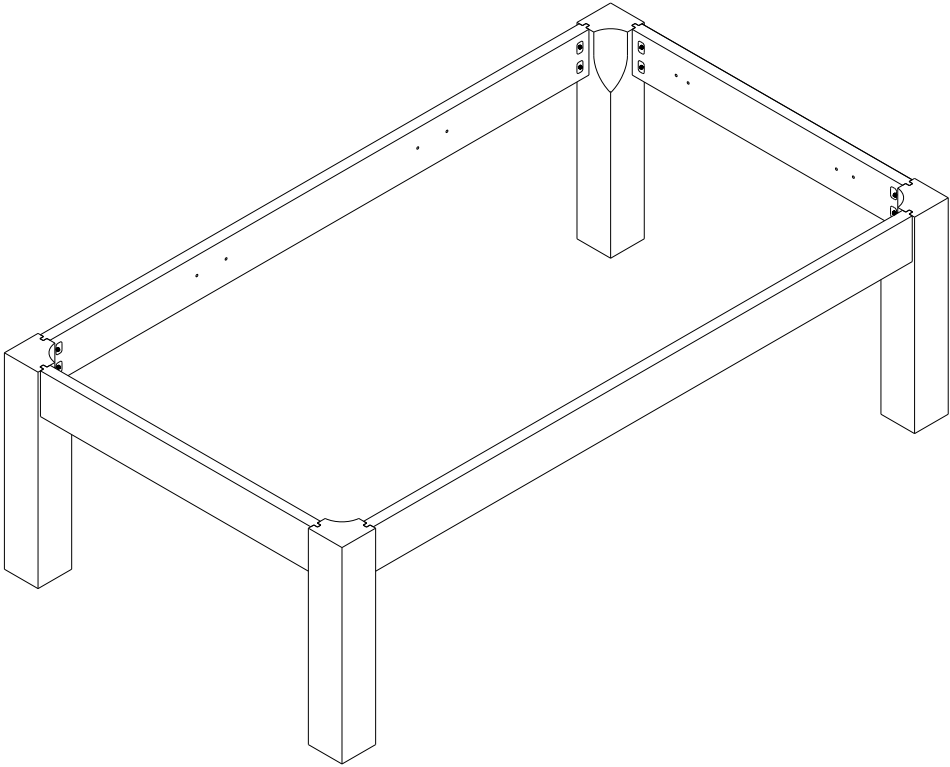


FIG.4

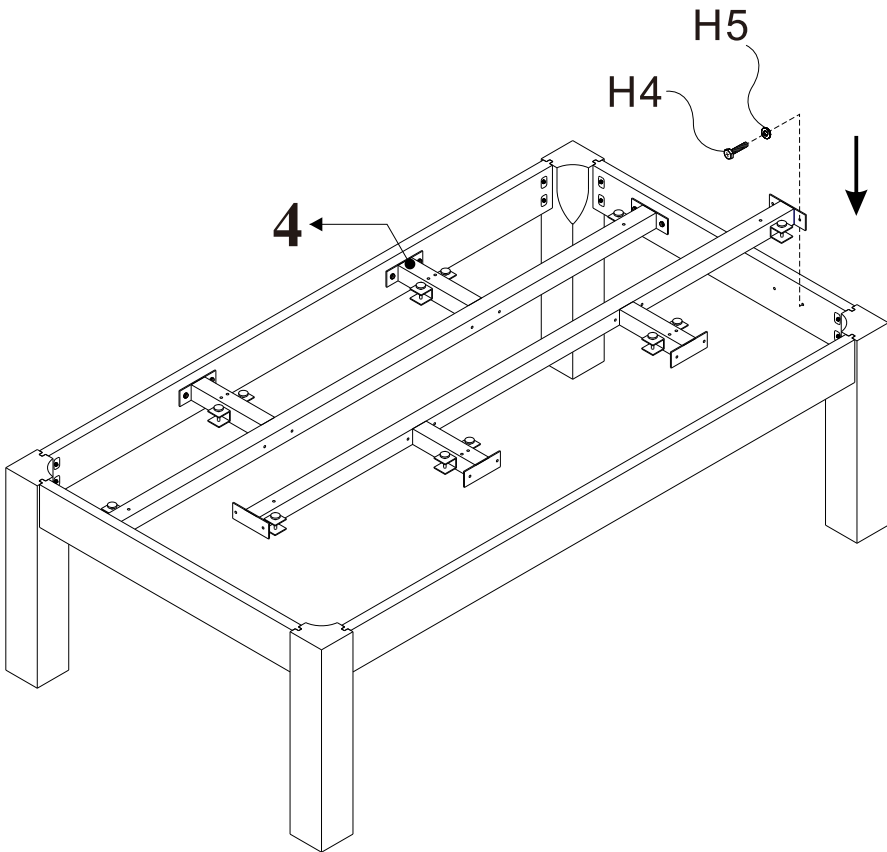


FIG.5

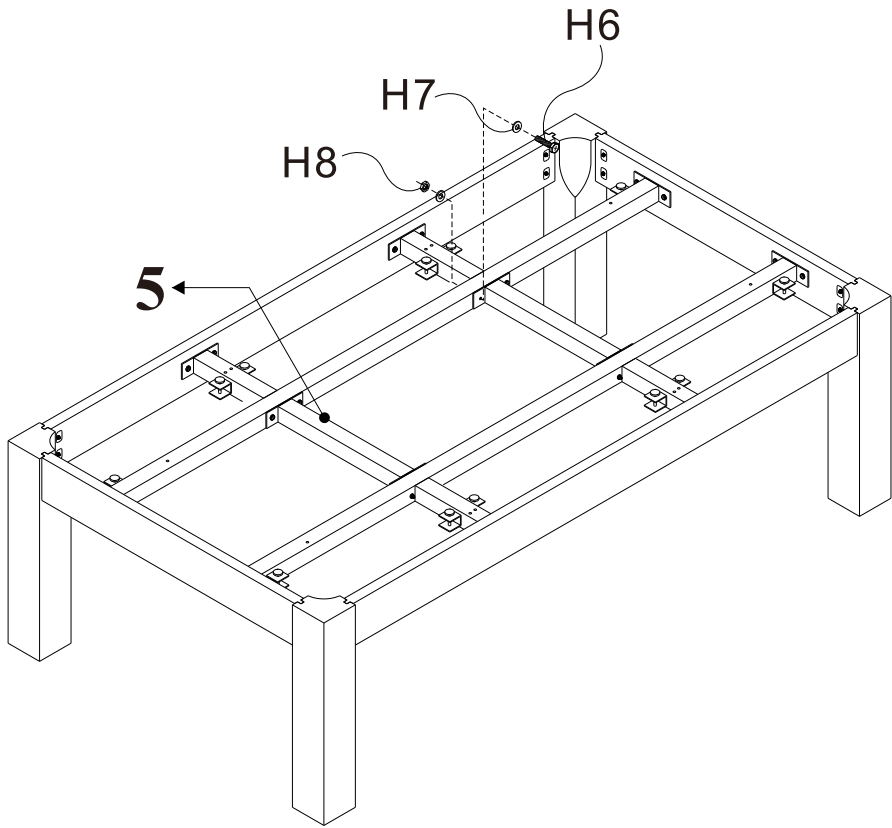


FIG.6

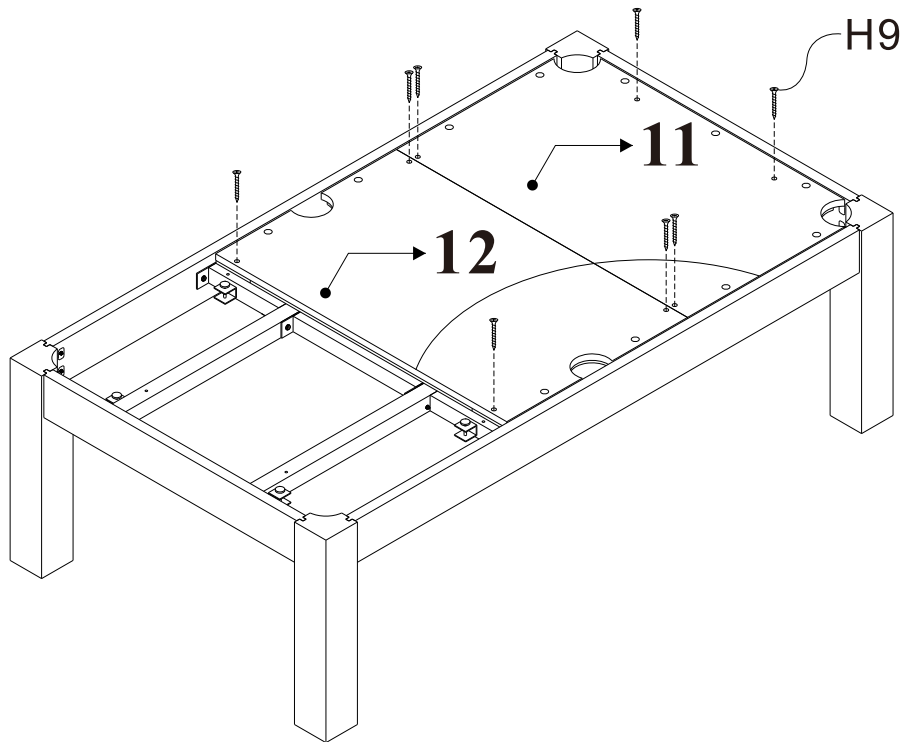


FIG.7

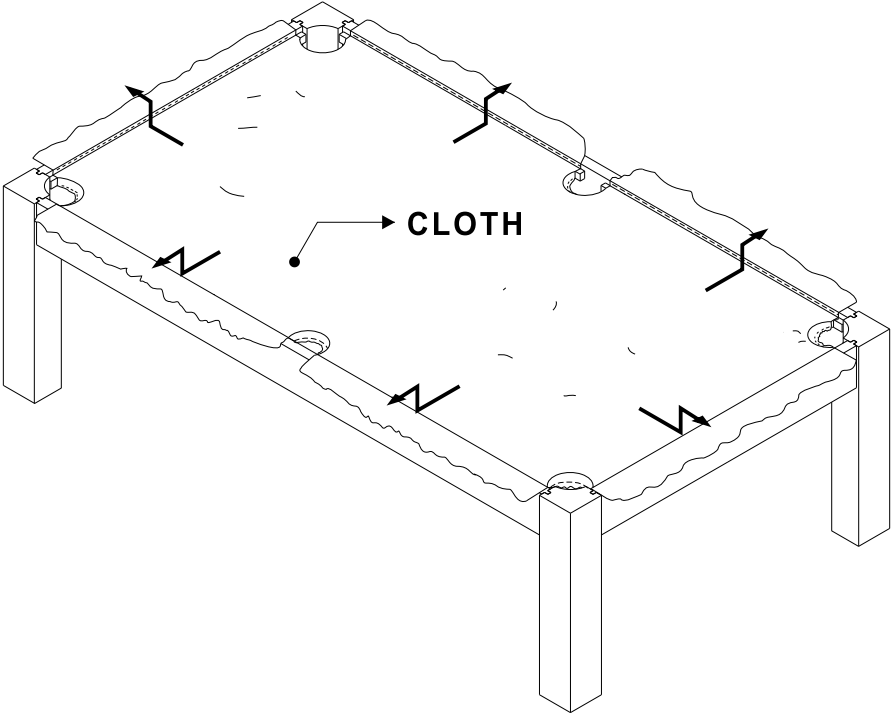


FIG.8

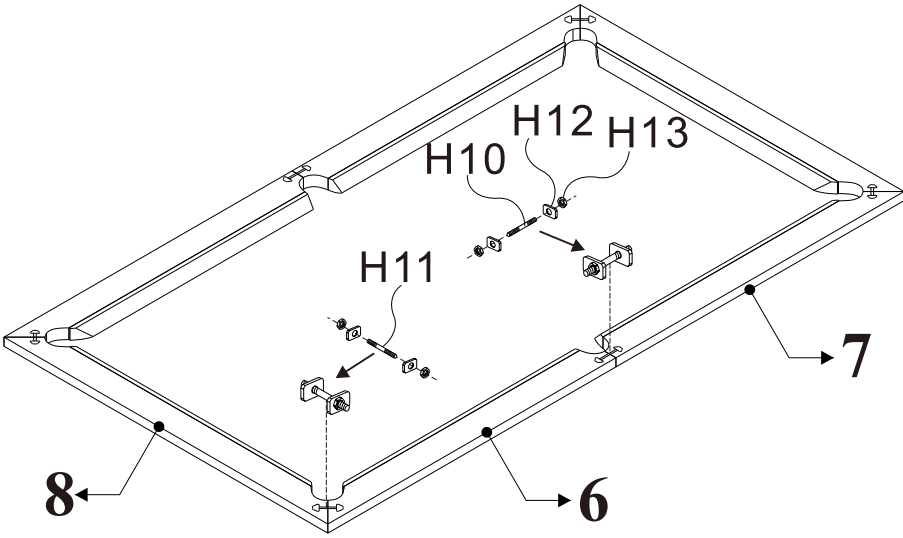
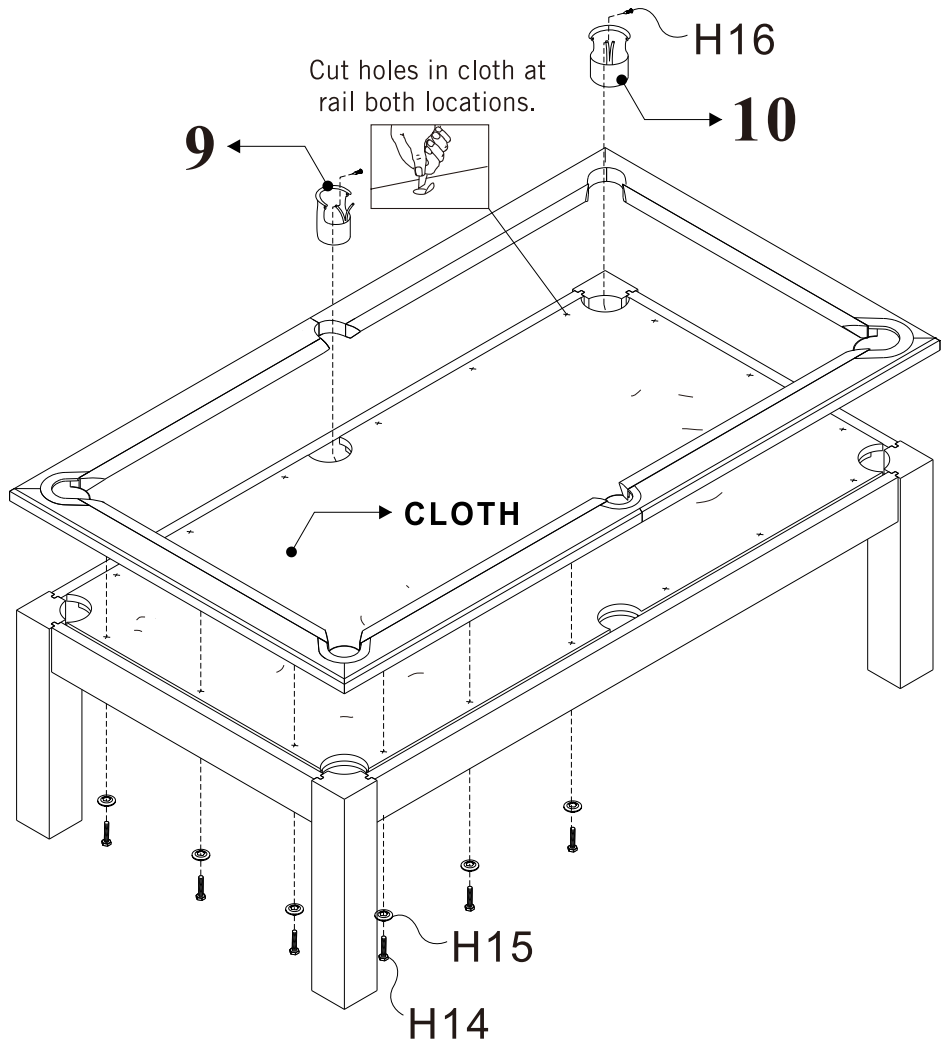


FIG.9



Finish

