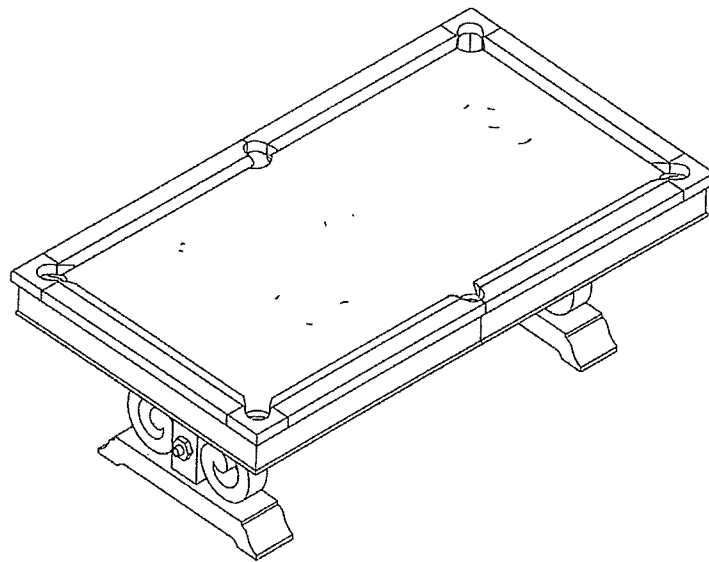
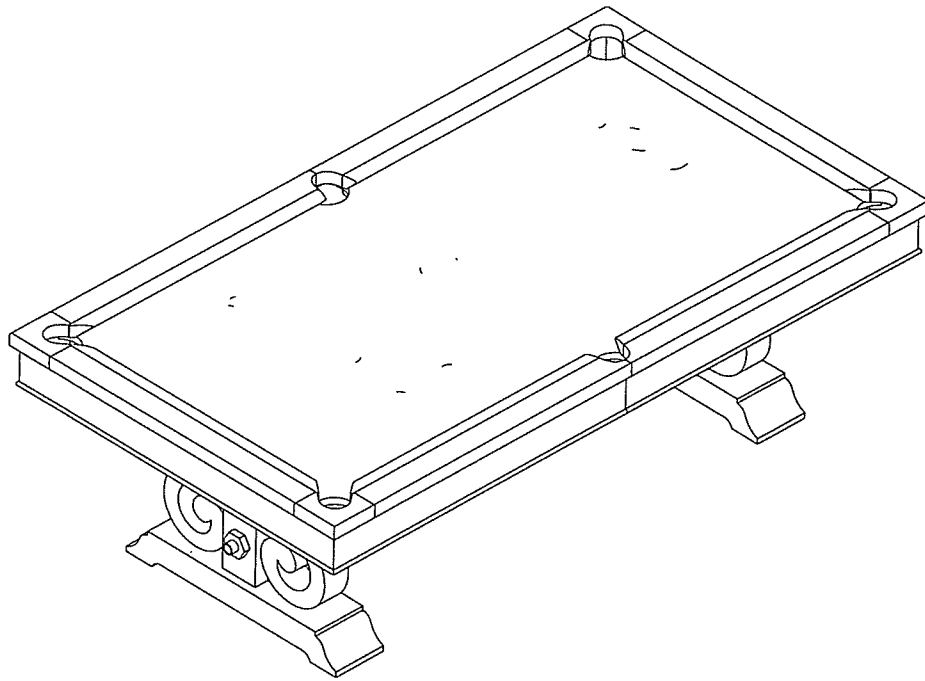


8' BARNSTABLE




















BARNSTABLE TABLE **ASSEMBLY INSTRUCTIONS**

8' BARNSTABLE



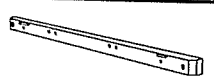








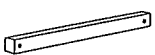






BARNSTABLE **TABLE** **ASSEMBLY INSTRUCTIONS**

REPLACEMENT PARTS LIST (HARDWARE)

PACKAGE	ITEM#	SAMPLE	DESCRIPTION	QTY.
LEG/PANEL	H1		HEX NUT 3/8" I.D.	2
	H2		HEX BOLT 3/8" X 5-1/8"	4
	H3		FLAT WASHER 3/8" I.D.	8
	H4		HEX BOLT 3/8" X 5-1/8"	4
	H5		HEX NUT 3/8" I.D.	4
BEAM/BLOCK	H6		FLAT WASHER 3/8" I.D.	8
	H7		HEX NUT 3/8" I.D.	4
	H8		HEX HEAD CROSS BOLT 5/16" x 2"	4
	H9		FLAT WASHER 5/16" I.D.	4
	H10		HEX HEAD CROSS BOLT 5/16" x 3-1/6"	16
	H11		FLAT WASHER 5/16" I.D.	16
RAIL/POCKET/SLATE	H12		FLAT HEAD SCREW 3/8" X 2-3/4"	12
	H13		STUD BOLT 5/16" x 5-1/2"	2
	H14		STUD BOLT 5/16" x 3-1/2"	8
	H15		FLAT WASHER 5/16" I.D.	20
	H16		HEX NUT 5/16" I.D.	20
	H17		HEX HEAD CROSS BOLT 5/16" x 1"	24

REPLACEMENT PARTS LIST

PACKAGE	ITEM#	SAMPLE	DESCRIPTION	QTY.
LEG	1		LEG	2
	2		LEG BEAM	1
	3		SIDE CABINET	2
FRAME(PANEL)	4		END CABINET	2
	5		LEFT SIDE APRON	2
	6		RIGHT SIDE APRON	2
	7		END APRON	2
	8		APRON JOINT CONNECTOR BLOCK	2
	9		APRON JOINT CORNER BLOCK	4
	10		LONG WOODEN BLOCK	4
	11		SHORT WOODEN BLOCK	4
	BEAM	12		CROSS BEAM
TOP RAIL	13		TOP RAIL LEFT SIDE	2
	14		TOP RAIL RIGHT SIDE	2
	15		TOP RAIL END	2
	16		TOP RAIL CORNER	4

REPLACEMENT PARTS LIST




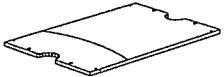


PACKAGE	ITEM#	SAMPLE	DESCRIPTION	QTY.
POCKET	17		SIDE POCKET	2
	18		CORNER POCKET	4
SLATE	19		SLATE (LEFT)	1
	20		SLATE (CENTER)	1
	21		SLATE (RIGHT)	1
	22		CLOTH	1

FIG.1

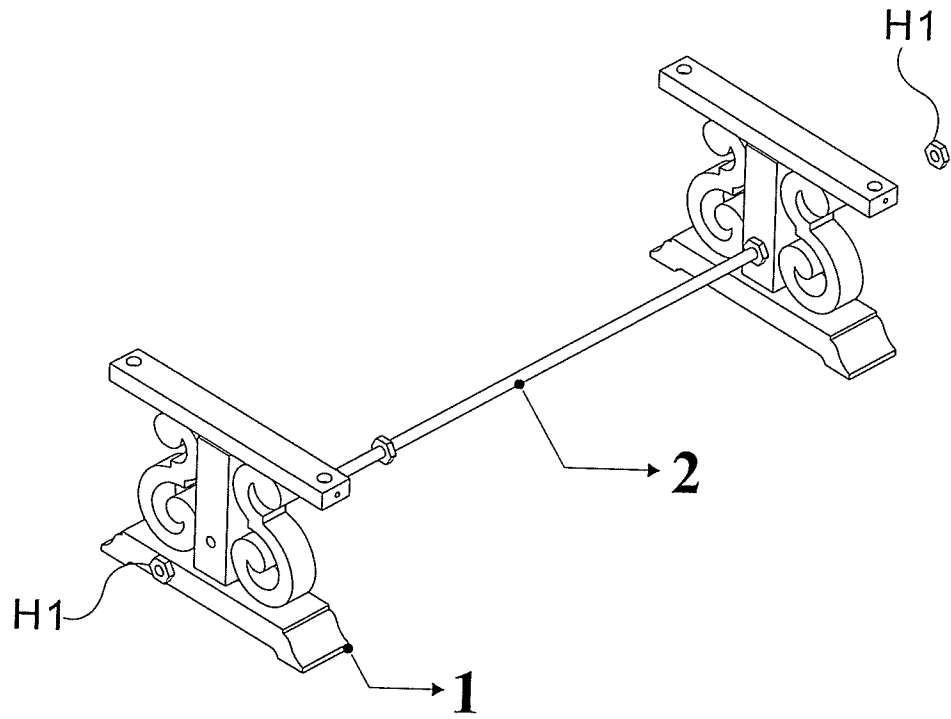


FIG.2

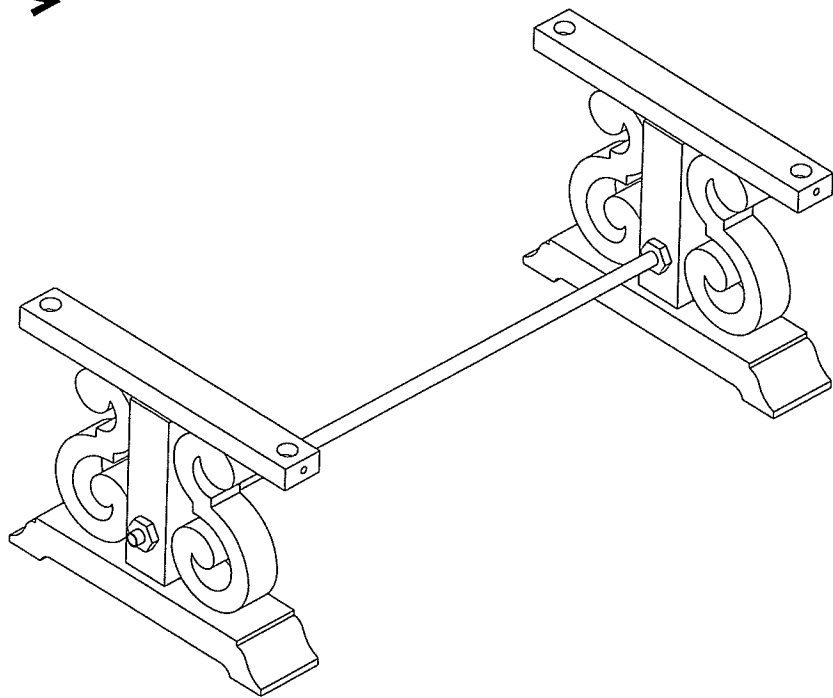


FIG.3

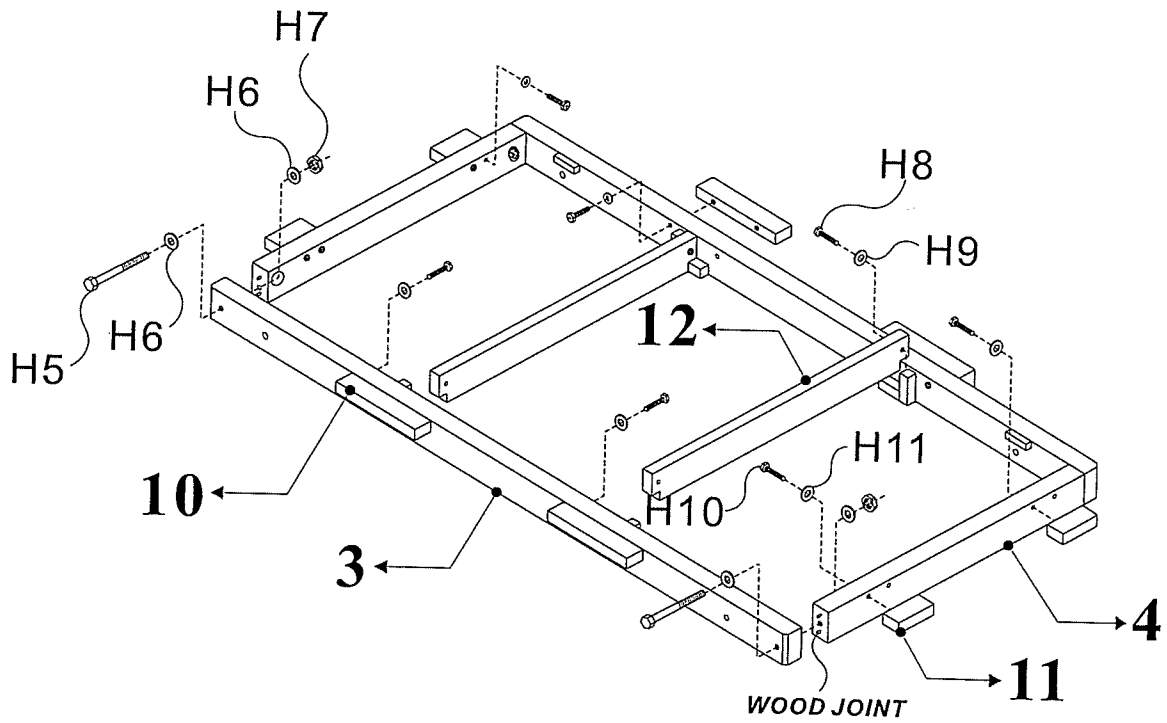


FIG.4

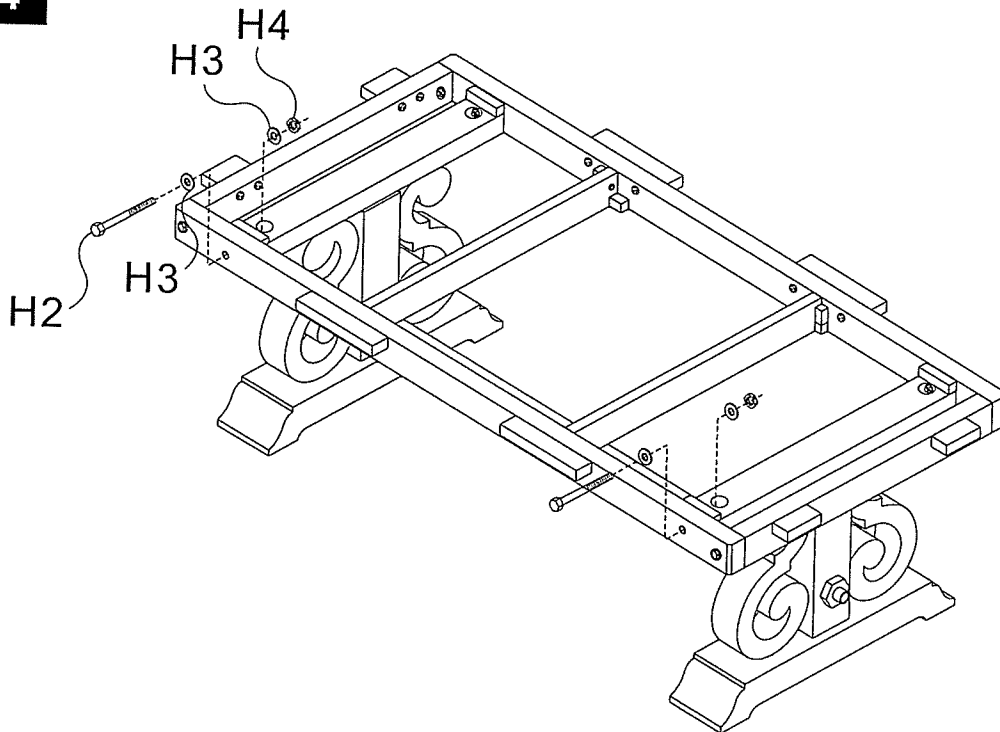


FIG.5

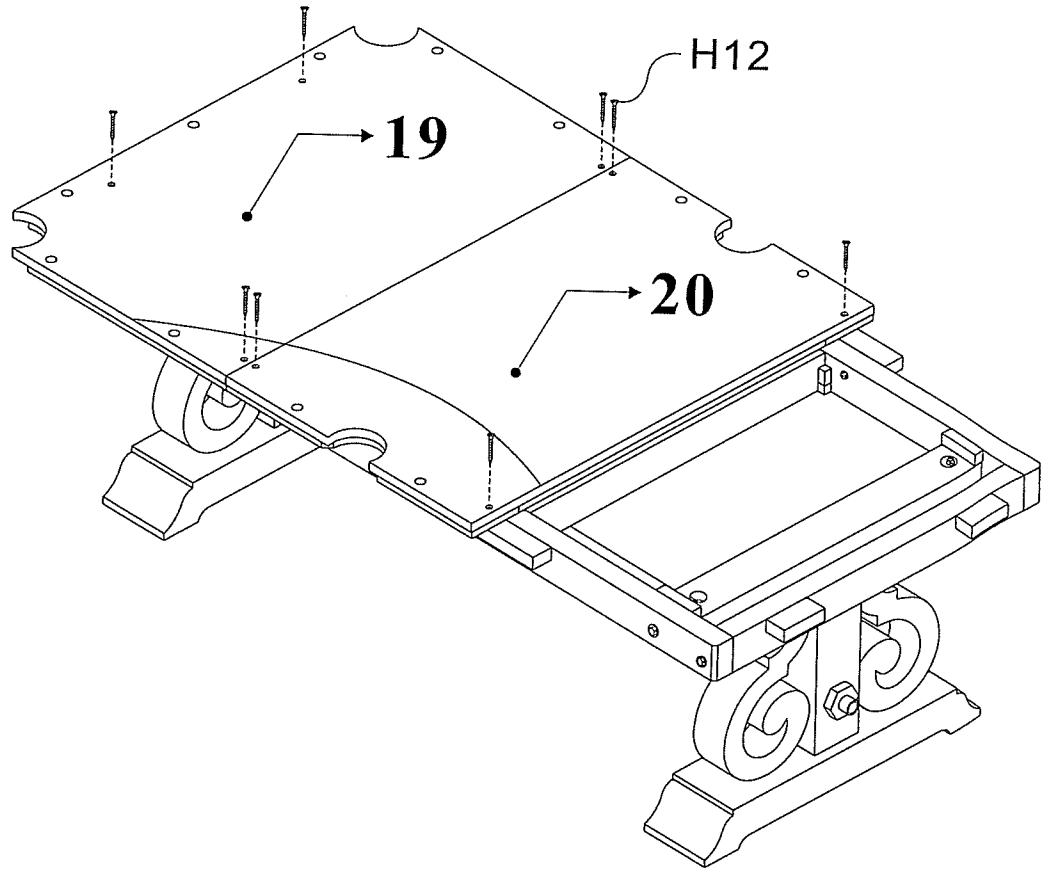


FIG.6

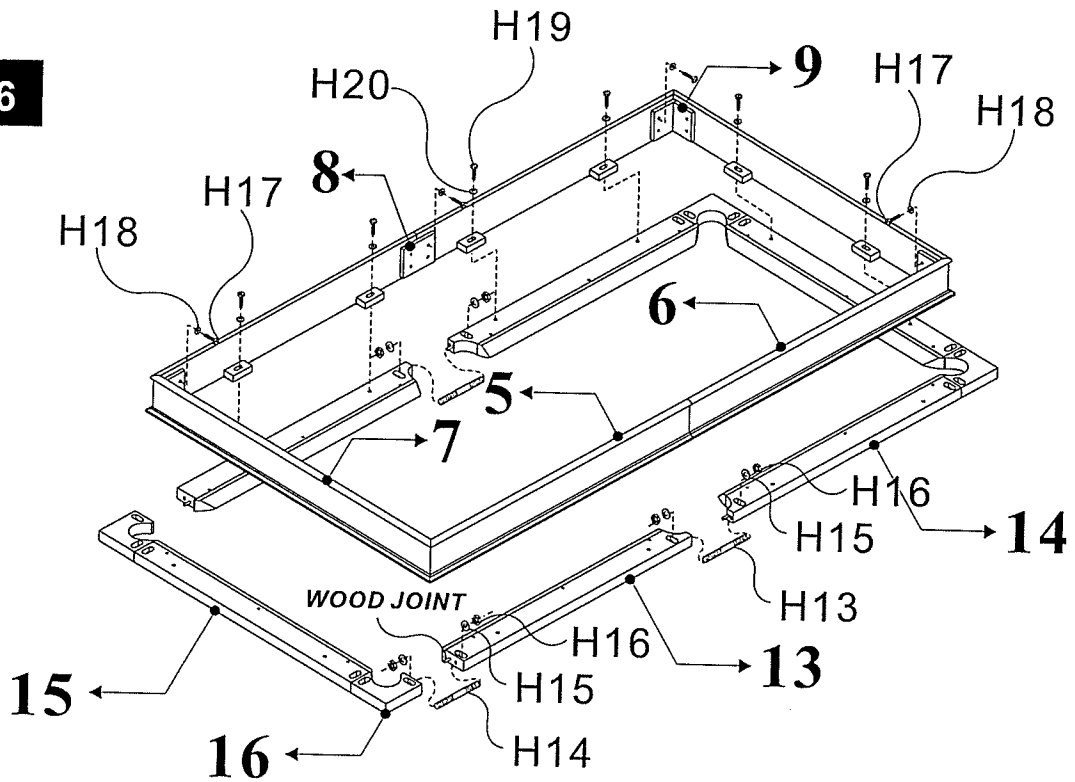
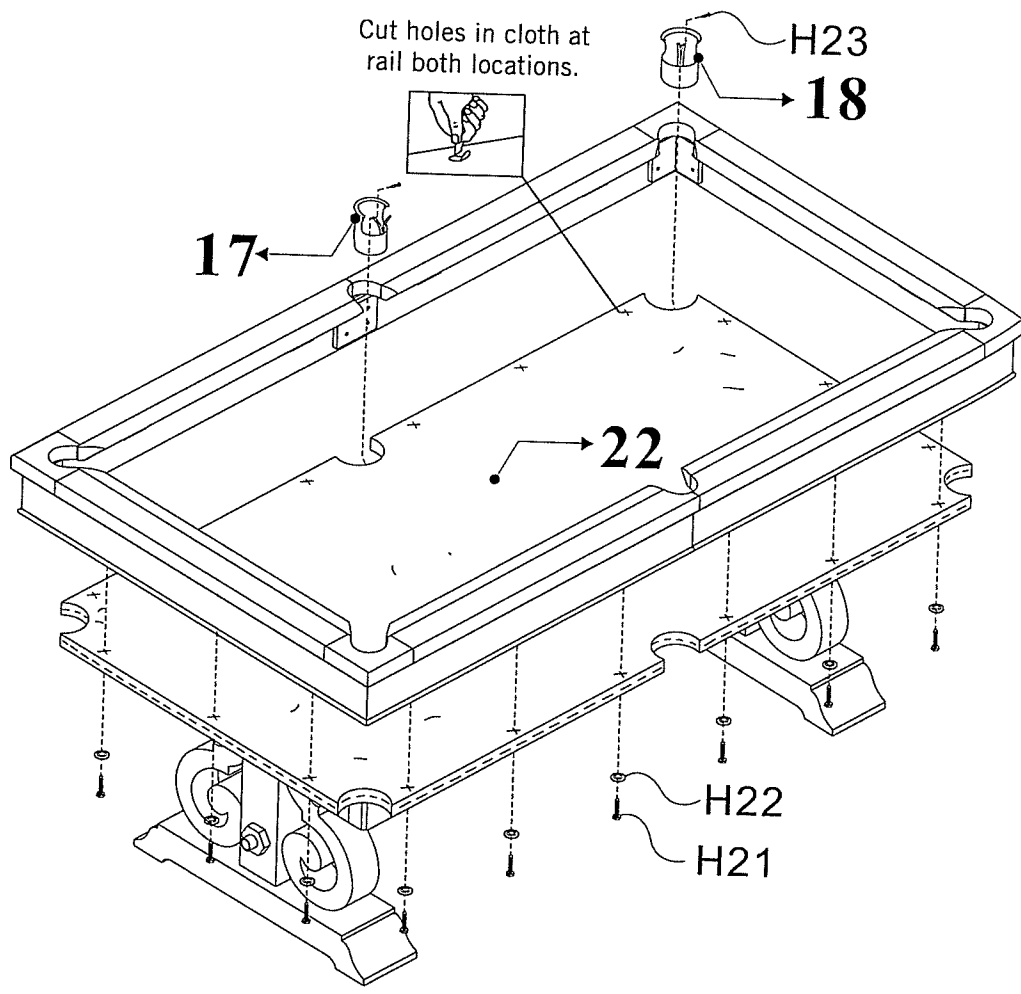


FIG.7



Finish

